

IOM A-0985A – SPI-MV
SINGLE POINT INSERTION FLOW METER VALVE
Installation and Operation Manual

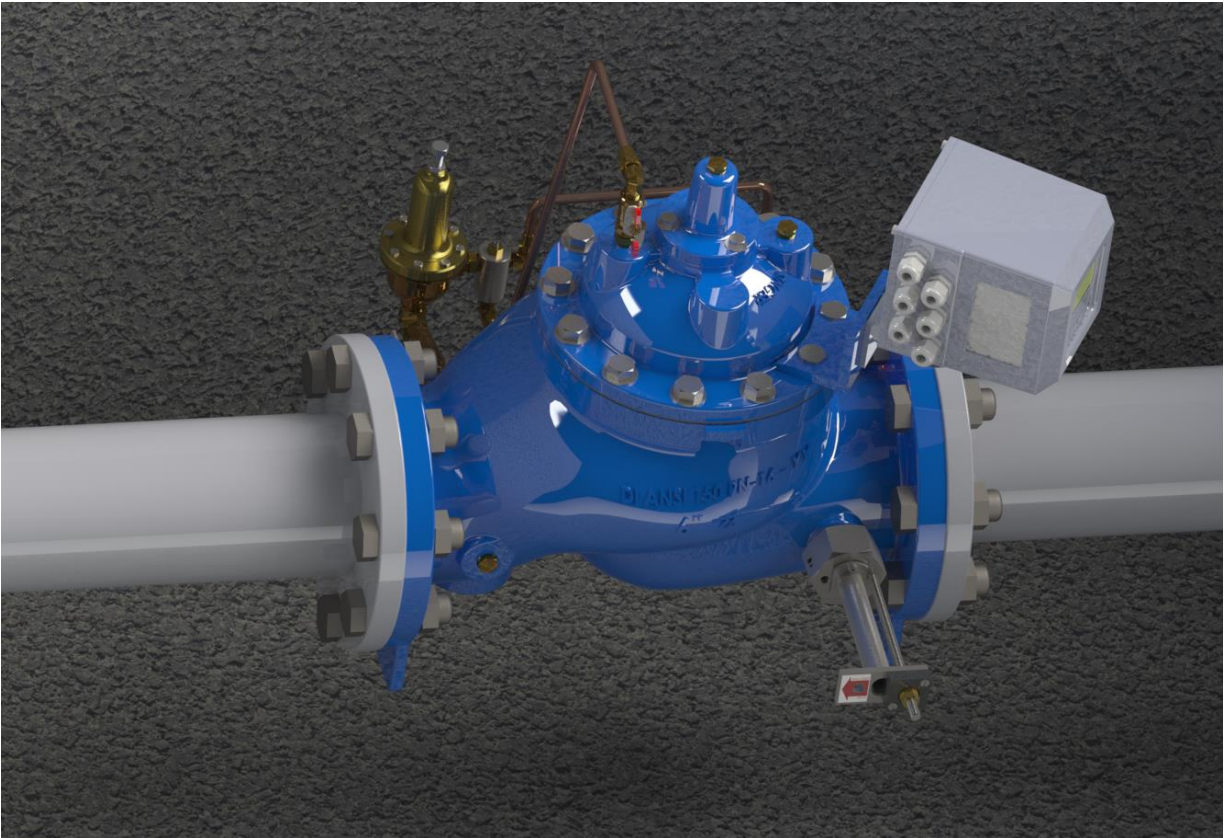

Please read and understand the contents of this manual.

Revision 2.0

Table of Contents

1	Health and Safety: Read First	1
2	Information.....	2
2.1	Design Information.....	2
2.2	Specifications	3
2.2.1	Flow Measurements	3
2.2.2	Power Requirements	3
2.2.3	Environmental Specifications.....	3
2.2.4	Material Specifications.....	3
3	Start-up Guide	4
4	Application Details	6
4.1	Basic Insertion Parameters.....	6
4.2	Exceptions.....	6
4.2.1	Gate Valve.....	6
4.2.2	Butterfly Valves.....	7
4.2.3	Reducers.....	8
4.2.4	Pumps.....	8
4.3	Anti-Cavitation Valve	8
5	Sensor.....	9
5.1	Insertion Hardware	10
5.2	Insertion Depth	11
6	Meter Removal	12
6.1	Maintenance.....	13
7	SPI Converter Overview	14
8	Converter Installation.....	16
8.1	Mounting the Converter	16
8.2	Installing Cables to Converter and Service Loop	16
8.3	Pulling Sensor Cable through Electrical Conduit.....	17
8.4	Sensor Cable.....	17
8.5	Sensor Electrical Cable Connections.....	18
8.5.1	Terminal Board.....	18
8.5.2	Sensor Wiring.....	19
8.5.3	4-20mA Hook-Up.....	20
8.5.4	Opto-Isolated Pulse Output Hook-Up.....	21
8.5.5	Converter Power Hook-Up.....	22
8.5.6	Converter Start-Up	23
8.6	Grounding.....	23
9	Menu Navigation.....	26
9.1	Front Panel Display	27
9.1.1	Factory Pre-Setting.....	28
9.2	SPI Menu Structure	29
9.3	Programming Example	30
9.4	Quick Start Menu.....	31
9.4.1	Fs1	31
9.4.2	Tot. MU.....	32
9.4.3	Pls1	32
9.4.4	Pls2.....	32
9.4.5	Tpls1	33
9.4.6	Tpls2	33



9.4.7	ND	33
9.4.8	Cutoff.....	33
9.4.9	Simulation.....	33
9.4.10	Contrast.....	34
9.4.11	Language	34
9.4.12	Main menu.....	34
9.5	Menu 1- Sensor.....	35
9.5.1	ND Inside Pipe Diameter	35
9.5.2	KA	35
9.5.3	Cable length	35
9.5.4	S. rate.....	35
9.5.5	E.P. Detect	35
9.5.6	E.I. cleaning.....	35
9.5.7	E.p. thr.....	35
9.5.8	Zero Cal.....	36
9.6	Menu 2 – Scales.....	36
9.6.1	Fs1	36
9.6.2	Tot. MU.....	37
9.6.3	Pls1	38
9.6.4	Pls2	38
9.6.5	Tpls1	38
9.6.6	Tpls2	38
9.6.7	Frq1.....	38
9.6.8	Frq2.....	38
9.7	Menu 3 - Measure	39
9.7.1	AC Filter	39
9.7.2	Damping.....	39
9.7.3	Cut-off	39
9.8	Menu 4 - Alarms	39
9.8.1	Max Thr +	39
9.8.2	Max Thr –	39
9.8.3	Min thr +	39
9.8.4	Min thr –	39
9.8.5	Hyst.....	40
9.8.6	mA v. fault	40
9.8.7	Hz v. fault	40
9.9	Menu 5 - Inputs.....	40
9.9.1	T+ reset.....	40
9.9.2	T- reset.....	40
9.9.3	Puls.reset	40
9.9.4	Count lock	40
9.10	Menu 6 - Outputs.....	40
9.10.1	Out 1	40
9.10.2	Out 2	40
9.10.3	Out 3	41
9.10.4	Out 4	41
9.10.5	Out mA1	41
9.10.6	Out mA2	41
9.11	Menu 7 - Communication.....	43
9.11.1	IF2 pr.....	43
9.11.2	RS485 bps.....	43



9.11.3	A. delay	43
9.11.4	Address	43
9.11.5	Rem. addr.....	43
9.11.6	Remote u.conn.	43
9.12	Menu 8 - Display.....	43
9.12.1	Language	43
9.12.2	Contrast.....	43
9.12.3	Quick start	43
9.12.4	Net total	44
9.12.5	T+ reset	44
9.12.6	T- reset.....	44
9.13	Menu 9 - Data Logger.....	44
9.13.1	YYYY/MM/DD.....	44
9.13.2	Acquisition	44
9.13.3	Display events	44
9.13.4	Clear events	44
9.14	Menu 10 - Diagnostics	45
9.14.1	Self-test	45
9.14.2	Simulation.....	45
9.14.3	Electrodes test.....	46
9.14.4	Signals	46
9.14.5	Display data.....	46
9.15	Menu 11 - Internal Data	47
9.15.1	L2 code.....	47
9.15.2	Load fact. Pres.	47
9.15.3	Load user pres.....	47
9.15.4	Save user pres.	48
9.15.5	KS	48
9.15.6	KZ.....	48
9.15.7	KZ-	48
9.15.8	DAC1 20mA	48
9.15.9	DAC1 4mA	48
9.15.10	DAC2 20mA.....	48
9.15.11	DAC2 4mA.....	48
10	Alarm Messages.....	49
11	Troubleshooting Guide	51
12	Appendix	52
12.1	Installation Guide.....	52
12.1.1	SPI Probe Installation:	52
12.1.2	Converter Wiring Installation:.....	57
12.2	Installation Record.....	60
12.3	Units of Measure	61

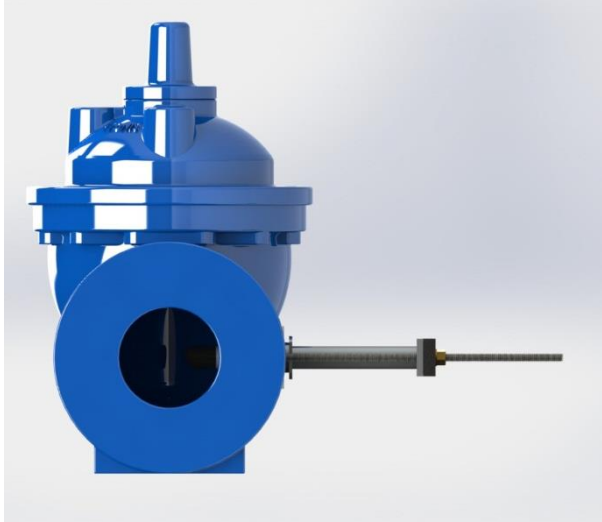

1 Health and Safety: Read First

Throughout this manual are safety warning and caution information boxes. Each warning and caution box will be identified by a large symbol indicating the type of information contained in the box. The symbols are explained below:



This symbol indicates important safety information. Failure to follow the instructions can result in serious injury or death.



This symbol indicates important information. Failure to follow the instructions can result in permanent damage to the meter or installation site.

When installing, operating, and maintaining equipment where hazards may be present, you must protect yourself by wearing Personal Protective Equipment (PPE) and be trained to enter confined spaces. Examples of confined spaces are manholes, pumping stations, pipelines, pits, septic tanks, sewage digesters, vaults, degreasers, storage tanks, boilers, and furnaces.

You must follow all state and local laws, as well as Occupational Safety And Health Administration (OSHA) regulations concerning Personal Protective Equipment, confined-space entry, and exposure to bloodborne pathogens.



WARNING!

Incorrect installation or removal of SPI Mag meters can result in serious injury or death. Read the instructions in this manual on the proper procedures carefully.



WARNING!

Never enter a confined space without testing the air at the top, middle, and bottom of the space. The air may be toxic, oxygen deficient, or explosive. Do not trust your senses to determine if the air is safe. You cannot see or smell many toxic gases.



WARNING!

Never enter a confined space without the proper safety equipment. You may need a respirator, gas detector, tripod, lifeline, and other safety equipment.



WARNING!

Never enter a confined space without standby/rescue personnel within earshot. Standby/rescue personnel must know what action to take in case of an emergency.



WARNING!

Pressurized pipes should only be hot tapped, cut, or drilled by qualified personnel. If possible, depressurize and drain the pipe before attempting any installation.



WARNING!

Carefully read all safety warning tags attached to the meter.

2 Information

Read this entire manual prior to installing the SPI and/or changing any settings. Retain this manual in your records. DO NOT DISCARD.

2.1 Design Information

With over 100 years of combined waterworks experience, Singer Valve and McCrometer have teamed up to provide a unique solution for in-valve flow measurement. Using McCrometer's proven Single Point Insertion Meter technology along with the reliability of a Singer Valve, the SPI-MV allows users to have both a flow meter solution along with any function of control valve. Whether it is pressure reducing, level control, or sustaining - all can now be installed with a very accurate flow meter solution. Combined with a dual solenoid control pilot system and a Singer Process Control Panel, the SPI-MV can provide flow feedback signals and perform automated flow control, and is capable of functioning within your existing SCADA system.

The Singer Model 106-SPI-MV is a Single Point Insertion Electromagnetic Flow Meter, installed and calibrated for a Singer valve to provide an accurate flow rate that can be utilized with the metering valve as a standalone option or built into a 106-2SC-PCO pilot system and panel to provide complete valve control. The SPI flow meter combines an innovative sensor with a comprehensive electronics package to provide accurate flow measurement for monitoring applications. The insertable sensor uses electromagnetic technology to measure water velocity. SPI has many features to suit a wide variety of applications, and is easily set up using the keypad and readouts.

The streamlined, debris-shedding sensor shape allows the SPI to be used under many flow conditions. The compact insertion design fits in confined spaces and offers complete accessibility. The flow meter can be removed for easy inspection and cleaning. This cost effective flow meter option is available for valve sizes from 3" (75mm) to 36" (900mm). The flow sensor comes pre-calibrated from McCrometer's NIST traceable Calibration Lab and requires no recalibration in the field. With no moving parts and a single-piece design, the SPI's sensor contains nothing to wear or break, and it is generally immune to clogging by sand, grit or other debris.

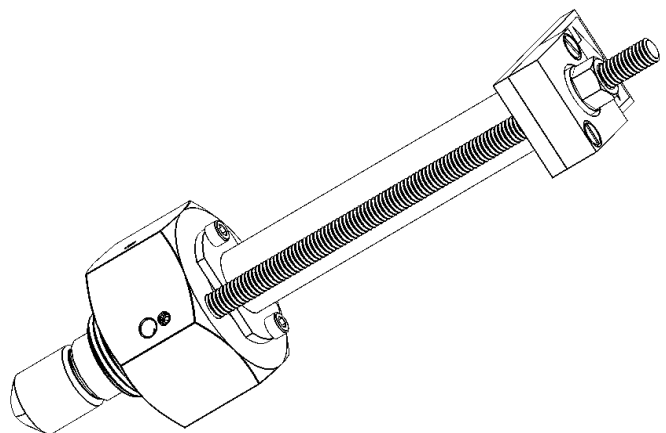
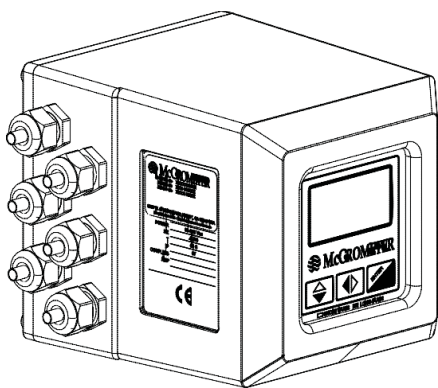

2.2 Specifications

2.2.1 Flow Measurements

Accuracy: +/-2% of reading +/- 0.03 ft/s zero stability

Velocity Range: +0.3 – 32 ft/s with reverse flow indication

2.2.2 Power Requirements

AC: 90 - 265V, 45 - 66 Hz (20W/25VA)

DC: 10 – 35V (21W)

****Note:** Specify power supply type when ordering

2.2.3 Environmental Specifications

Insertion Tube Operating Temperature: Up to 160°F (71°C) at 250 PSI

Insertion Sensor Rating: IP68 (submersible)

Local Converter Operating Temperature: -4°F to 140°F (-20°C to 60°C)

Local Converter Enclosure Rating: IP67 (Temporary Immersion in up to 7ft)

2.2.4 Material Specifications

Probe Head: Polyurethane

Probe Pipe Sleeve: 316 Seamless Stainless Steel Pipe

Electrode: 580 Grade Carbon Rod

Nipple & Compression Assembly: 316 Stainless Steel

Compression Seal: Buna "N" O – Ring Seal

Thread Seal Between Probe and Probe Pipe: Mixture of Loctite 7649 and Loctite 564

Thread Sealant Tape between Nipple & Valve: PTFE

Sensor Cable: Twinmax Polyurethane

Local Converter Enclosure: Die Cast Aluminum (Standard)

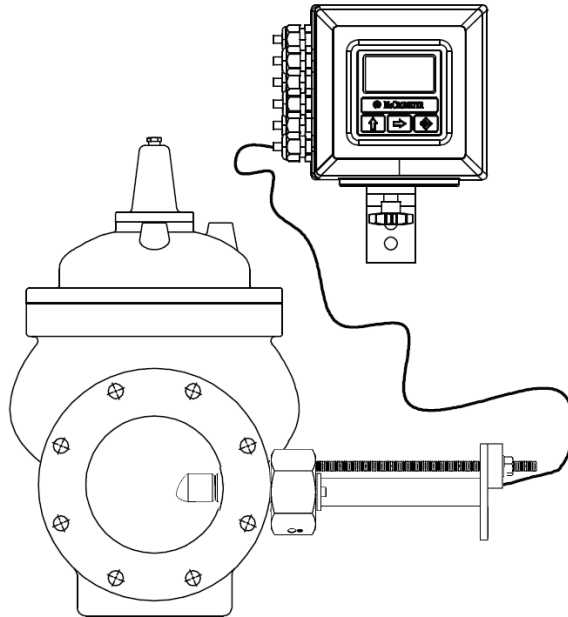

3 Start-up Guide

WARNING: Read all manual sections referred to by this guide for full instructions and ensured safety.

NOTE: If SPI Sensor is not factory installed in the Singer Valve please refer to Appendix 12.1. for Step-by-step install instructions before proceeding with Start-up Guide.

NOTE: Where required, the **L2 Passcode is 000002.**

Basic Start-up Site Requirements Checklist:

- External power available to power SPI-MV.
- Pipe primed and pressurized with water.
- Ability to shut off flow and isolate Singer valve for zero flow calibration.
- Ability to flow varying flow through valve.

Proper Installation Checklist:

- Verify SPI-MV is installed with sufficient straight pipe upstream of the valve. See Section 4: *Application Details.*
- Verify SPI-MV sensor probe and the converter are grounded to a grounding ring, grounding rod, or similar. See section 8.6: *Grounding.*

Before Powering the SPI Convertor Checklist:

- Verify the correct power type (AC/DC) is being used by checking the SPI-MV convertor data plate. In AC convertors the power terminal block is green. In DC convertors the power terminal block is red. See section 8.5.1: *Terminal Board.*
- Verify the power wires (L/N/G, or L1/L2/G, or 24V/0V/G) are wired to the SPI-MV convertor correctly. See section 8.5.5: *Converter Power Hook-Up.*
- Verify the SPI-MV sensor probe wires are wired to the SPI-MV convertor correctly. See section 8.5.2: *Sensor Wiring* for more details.
- If 4-20mA outputs or Pulse Outputs are being used, verify wires are wired to the SPI-MV convertor correctly. See sections 8.5.3 and 8.5.4 for more details.
- Verify all cables entering the converter are through the built-in cable compression glands and that all glands are tightened to maintain the converter's IP67 rating. See section 8.2: *Installing Cables to Converter and Service Loop* for more details.
- Ensure the SPI-MV convertor rear panel is closed tightly to maintain the converter's IP67 rating.

During Converter Power-up Checklist:

- Ensure converter powers up and passes self-test. See section 8.5.6: *Converter Start-Up*.
 - If convertor fails self-test, error codes will display. Contact factor for support.

Converter Configuration Checklist:

- Use Left/Right arrow to navigate, See section 9.1 Front Panel Display to the Alarms Menu. Ensure there are no alarms present. If alarms are present See section 10 Alarm Messages.
- Press Enter/Esc to access the Quick Start Menu. See section 9.4.
- Perform Zero Calibration – See section 9.5.8: *Zero Cal*.
- Set Flow Range and Units – See section 9.4.1: *Fs1*.
- Use Left/Right arrow to navigate, See section 9.1 Front Panel Display to the preferred display to be maintained during operation.

NAME:

DATE:

SIGNED:

4 Application Details

4.1 Basic Insertion Parameters

For most application you need 3 Pipe diameters straight pipe upstream flange to flange from any in-line device, elbow, or tee.

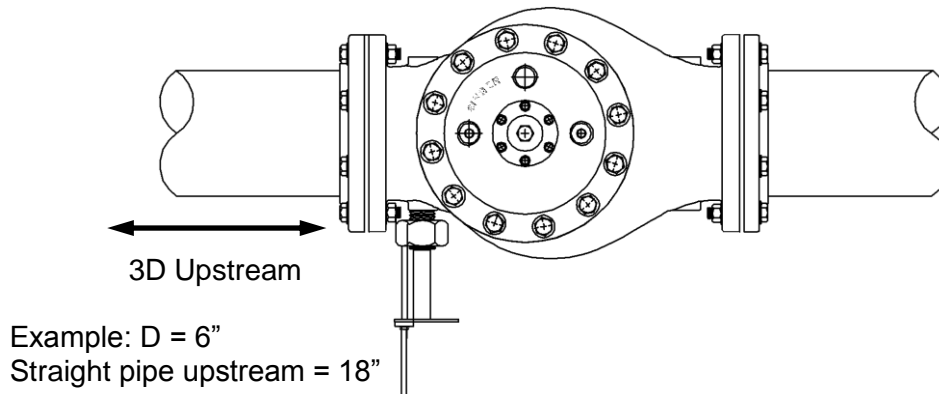

Figure 1: SPI-MV Basic Insertion

4.2 Exceptions

4.2.1 Gate Valve

Gate valve fully open will not cause any effect and can be mounted next to SPI-MV valve. Gate valve not fully open will cause a flow disturbance and will need 3D from SPI-MV valve

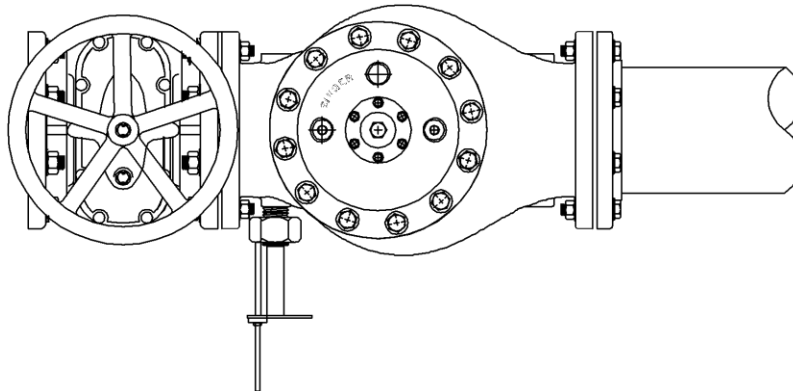

Figure 2: SPI-MV with Gate Valve

4.2.2 Butterfly Valves

A horizontal butterfly valve will cause a larger flow disturbance and will need three pipe diameters from SPI-MV valve

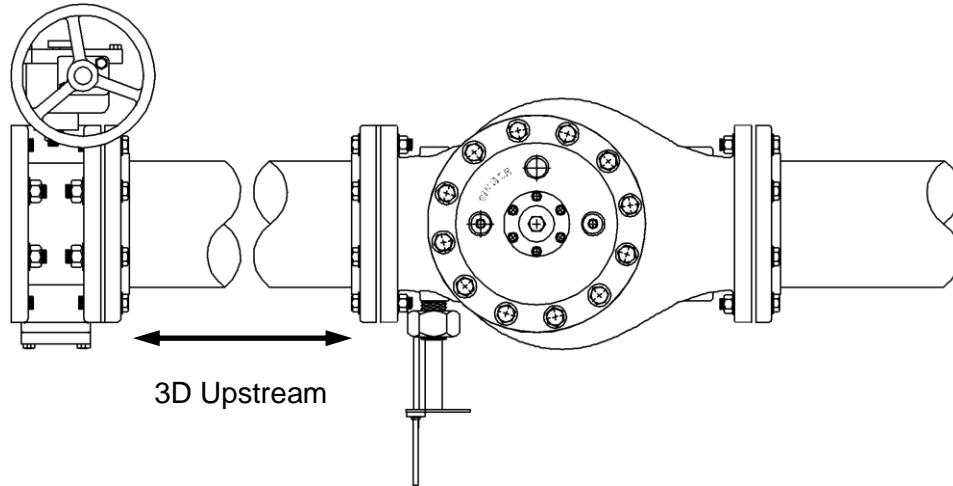

Figure 3: SPI-MV with Horizontal Butterfly Valve

A vertical butterfly valve fully open will cause a small disturbance and therefore will need only one pipe diameter to the SPI-MV valve.

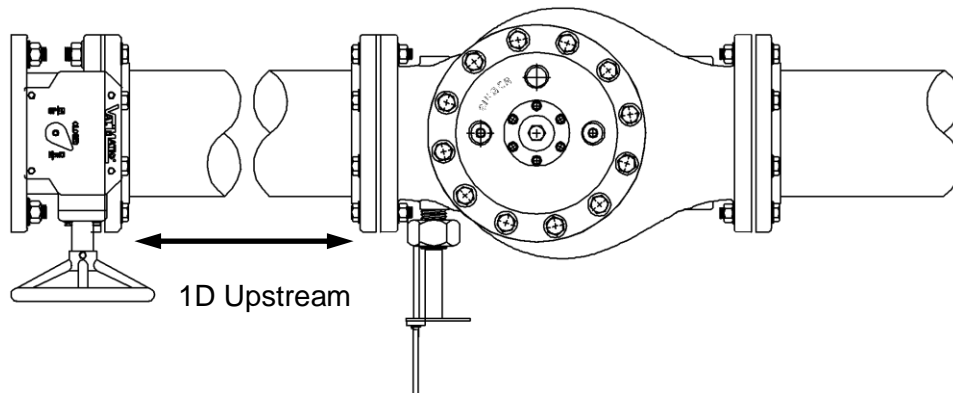
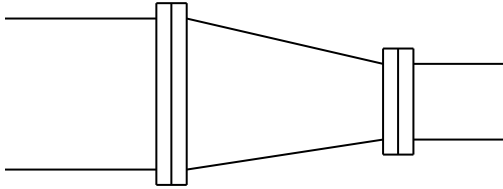

Figure 4: SPI-MV with Vertical Butterfly Valve

4.2.3 Reducers

Concentric Reducer: Does not affect system



Eccentric Reducer: 3D required

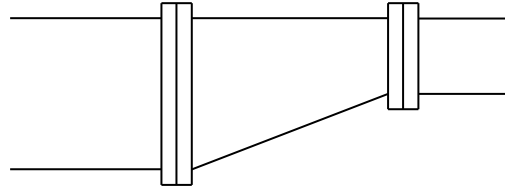

Figure 5: Reducers

4.2.4 Pumps

Pumps usually have a check valve which works well to stabilize flow, therefore use the usual 3 pipe diameter upstream after check valve for pump applications.

4.3 Anti-Cavitation Valve

During high pressure loss across a valve, the valve may experience cavitation. When cavitation occurs across the valve, the SPI-MV will experience a decrease in accuracy. An application where cavitation may occur is rectified by having a Singer Valve fitted with a Singer Anti-Cavitation Cage. If the valve is fitted with an anti-cavitation cage, the SPI-MV is able to maintain its high precision of accuracy. However, each cage is customized to the application and special testing is required to calibrate the SPI-MV when fitted with a cage.

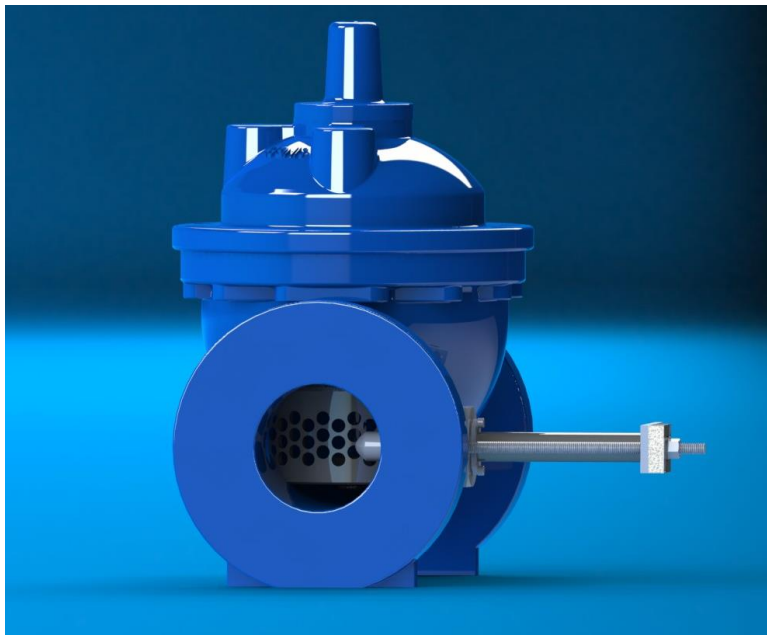

Figure 6: SPI-MV with Anti-Cavitation Cage

Check with a qualified Singer representative or contact Singer directly to see if your system will experience cavitation.

5 Sensor

The SPI insertion sensor makes use of Faraday's Law of Electromagnetic Induction to measure water velocity. Faraday's Law states:

A conductor, moving through a magnetic field, produces a voltage.

Because water is a conductor, water moving through a magnetic field produces a voltage. The magnitude of the voltage is directly proportional to the velocity of the water. The sensor generates an electromagnetic field in the water. A faster water velocity produces a higher voltage. The two velocity electrodes, along with the ground electrode measure this voltage. By accurately measuring this voltage, the velocity is determined.

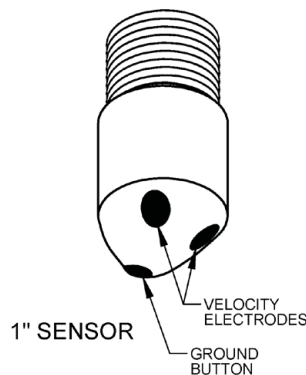

Figure 7: Sensor Electrodes

The velocity measurement provided by the sensor is used to calculate flow. Flow is the amount of fluid moving through a pipe in a period of time. To calculate the flow, two things are needed: The cross-sectional area of the pipe and the average velocity.

$$\text{Flow} = \text{Average Velocity} \times \text{Area}$$

Each sensor is paired with a Converter that performs these calculations to convert the sensor signal into a flow value. The converter displays the flow on screen as well as retransmitting it as a 4-20mA signal.

5.1 Insertion Hardware

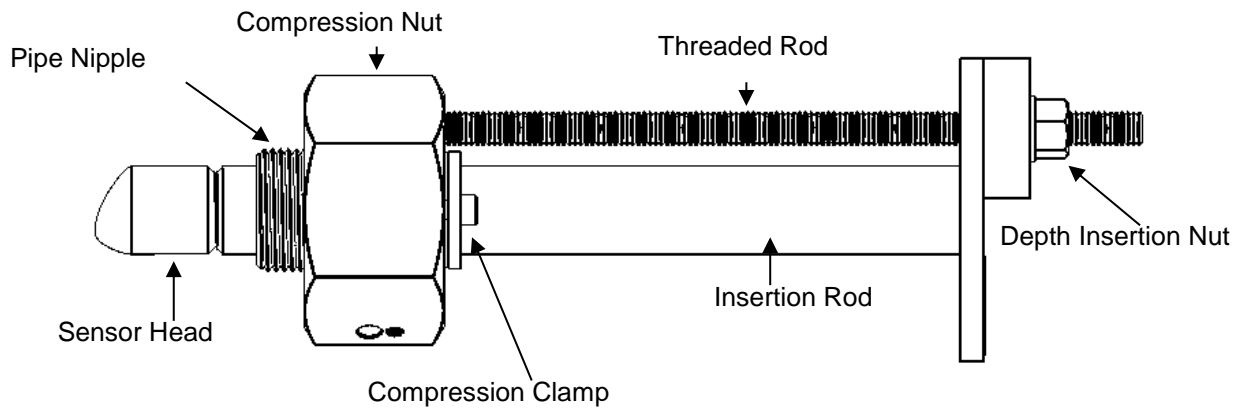
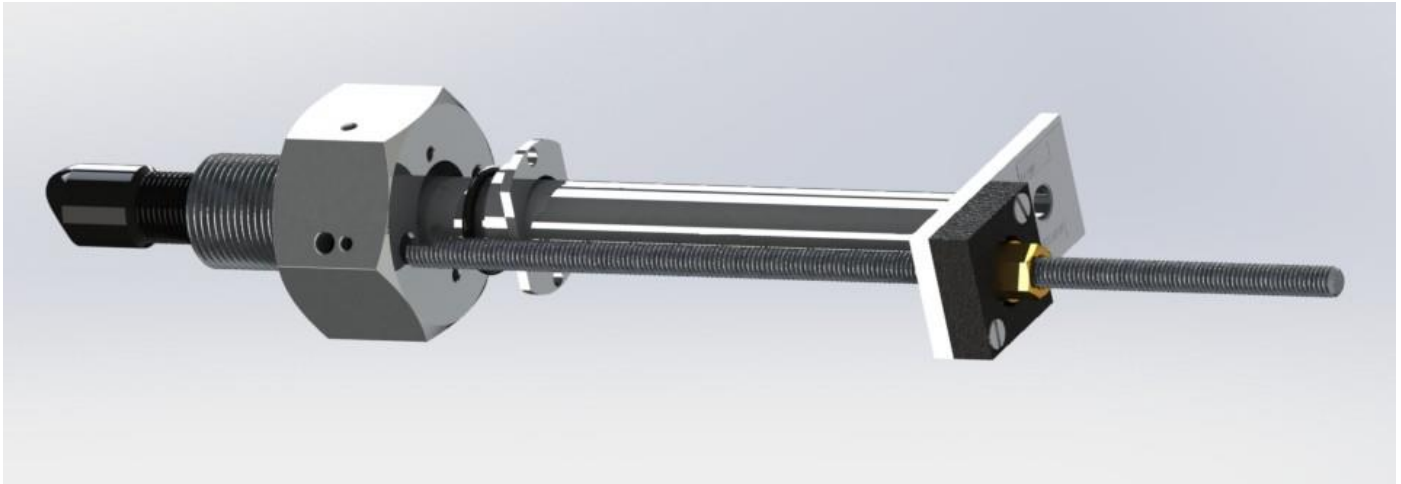

Figure 8: SPI Probe Insertion Assembly

5.2 Insertion Depth

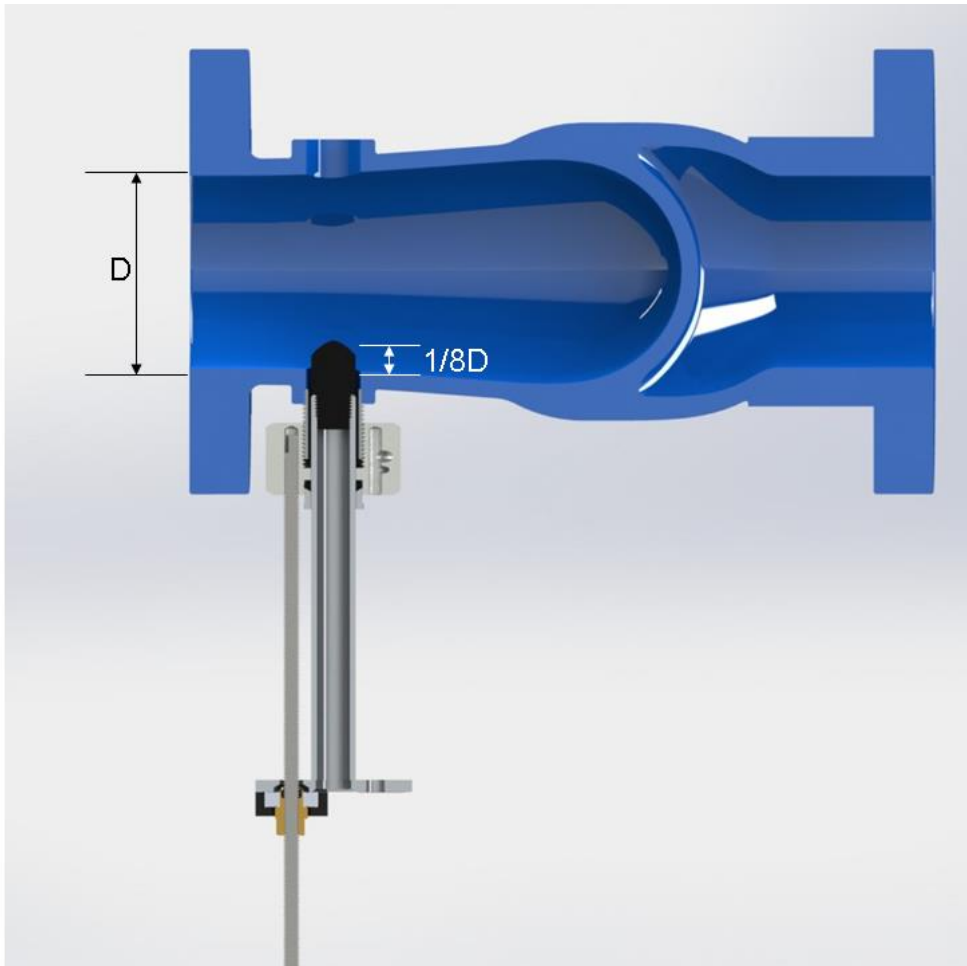

Figure 9: Probe Insertion Depth

McCrometer calibrates the SPI-MV sensor to calculate flow of the valve at an insertion depth of $1/8$ the diameter of the valve. The $1/8$ insertion depth is measured from the internal boss edge to the sensor electrodes. Singer will install the SPI sensor into main valve at the correct insertion depth before all orders are shipped. An insertion clamp lock nut will be added to the threaded rod to ensure that the sensor is maintained at this depth. See *Appendix 12.1 Installation Guide* for detailed installation instructions.

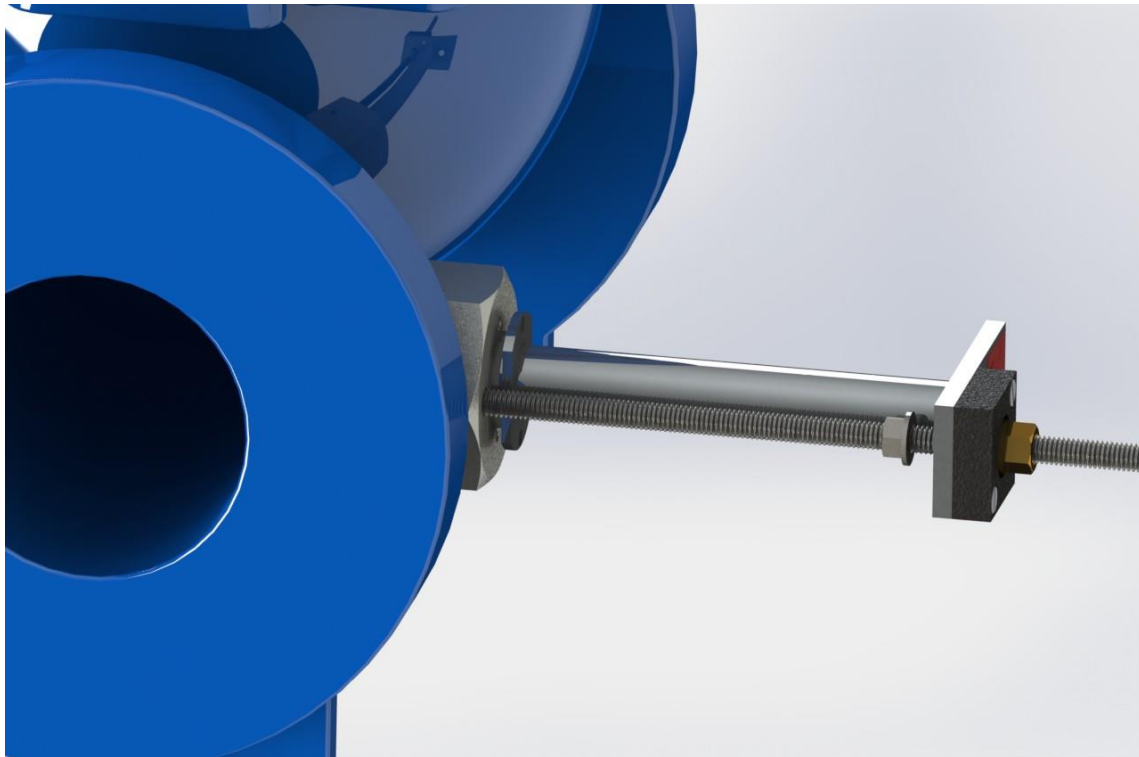

Figure 10: Installed Probe with Clamp Nut

NOTE: Do not remove the insertion clamp nut. An offset of insertion depth will cause an incorrect reading. A lock nut or two jam nuts may be used in place of a clamp nut. At minimum, the correct depth must be marked on the threaded rod before removal.

NOTE: Old style Singer valves bodies **cannot** be retrofitted to have an SPI meter.

6 Meter Removal

To remove the meter, follow the steps below:



WARNING!

The pipe may be under pressure. Serious injury or death may result if proper procedures are not followed.

DEPRESSURIZE THE LINE BEFORE ATTEMPTING REMOVAL OF THE SENSOR.

Loosen the compression clamp seal with an Allen key until the seal just begins to leak. This will relieve the pressure on the compression seal allowing the sensor to be removed. Draping a towel around the compression seal can reduce any spraying water.

Rotate the Depth Insertion Nut to start removing the sensor. This will cause the sensor to rise out of the compression nut and move along the threaded rod. Completely unthread the sensor off the threaded rod to remove the sensor from the valve.



Figure 11: Removing Probe



Figure 12: Valve with Probe Removed

6.1 Maintenance

The SPI is essentially a maintenance free meter with no user serviceable parts. However, the metered fluid may contain solids or other contaminants that coat the sensor electrodes. A periodic inspection may be recommended to ensure the sensor electrodes are clean. To clean the unit, remove the sensor following all of the instructions and safety warning contained in Section above. Once the sensor is removed from the pipe, carefully wipe down the sensor with a soft cloth and a mildly abrasive detergent, such as a liquid kitchen detergent. Once the sensor is clean, reinsert the sensor by rotating the Depth Insertion Nut until the sensor end butts up against the Insertion Clamp Nut. Tighten the Compression Seal and ensure the sensor is level again.

7 SPI Converter Overview

The SPI Signal Converter is the reporting, input and output control device for the sensor. The converter allows the measurements, control of the sensor and data recording to be communicated through the display and inputs & outputs. The SPI microprocessor-based signal converter has a twelve-point curve-fitting algorithm to improve accuracy, dual 4-20mA analog outputs, and an 8-line graphical backlit LCD display with 3-key touch programming. The converter will output rate of flow and total volume. The converter also comes standard with password protection and many more features.

The converter is available in both local (Figure 13) and panel mount (Figure 14) configurations. Local Converters are IP67 rated and stand-alone while Panel-Mount Converters are IP65 rated and intended for integration into a control panel inside an enclosure.

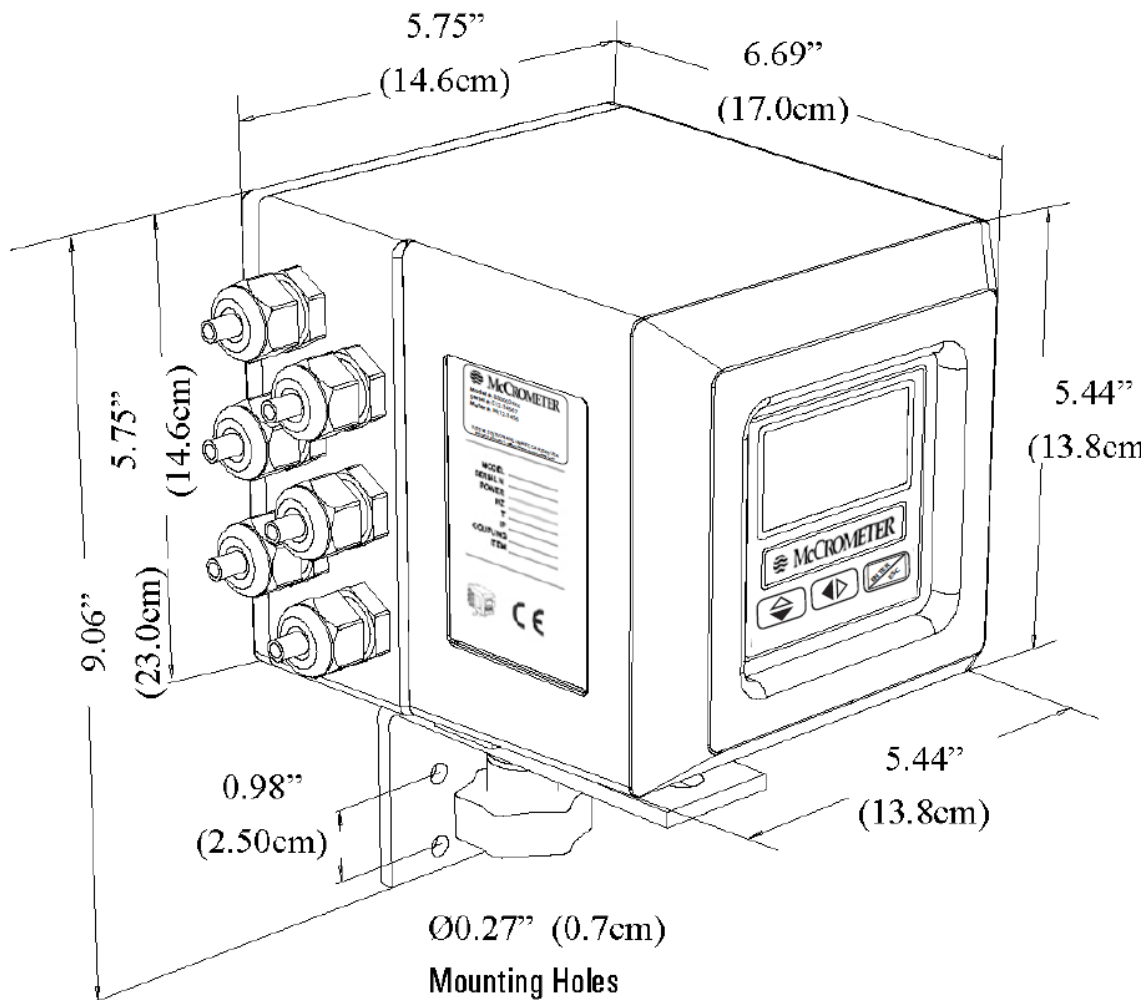

Figure 13: Local Converter Dimensions

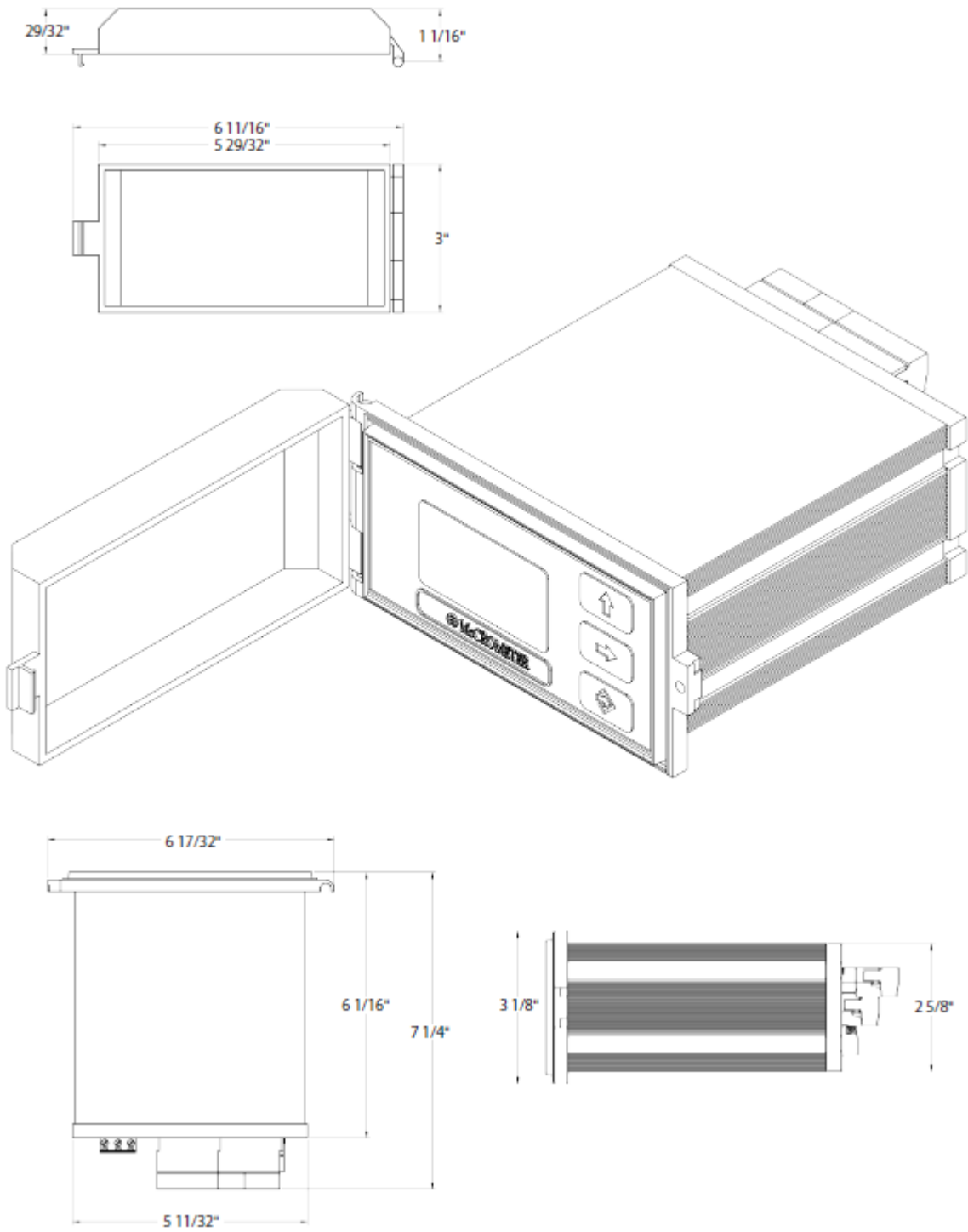

Figure 14: Panel-Mount Converter Dimensions

8 Converter Installation

8.1 Mounting the Converter

If possible, mount the converter in an electronics shed or environmental enclosure. If the converter is mounted outdoors a sun shield is recommended. The sun shield should be oriented in a direction to reduce sun damage and ensure readability. The Local Converter is mounted using 2 bolts. The Panel-Mount Converter is secured to a panel using two screws. A service loop in the cables is required.

8.2 Installing Cables to Converter and Service Loop

Any cable running through a conduit must exit the conduit and have a minimum of an 8" service loop before entering the electronics enclosure through the cable glands. All cable compression glands must be properly tightened to prevent moisture intrusion and maintain the IP67 rating. This allows the electronics enclosure to be rotated and the rear panel to be accessed. If electrically bonding (grounding) the enclosure to metallic conduit or raceways, secure a lead wire to the enclosures back panel screw and attach the lead to a listed and approved conduit grounding bushing. To ensure IP67 rating use only round cable 0.125" to 0.375" in diameter.



IMPORTANT: Do not cut or alter the cable length on power or signal cables!

Connections to the sensor must be made with cable supplied by McCrometer specifically for that purpose. Do not substitute the supplied cable with other types of cable, even for short runs. For repairs or added lengths of cable, the entire cable between the sensor and the converter must be replaced. (Consult factory for replacement cable.)



WARNING: Do not connect any form of conduit directly to the converter enclosure. Doing so will allow moisture and potentially dangerous gasses to enter directly into the converter. Attaching any conduit to the enclosure, or altering the enclosure in any way will void the warranty.

Attaching conduit to the enclosure or altering the enclosure in any way will remove the IP67 rating and void the warranty.

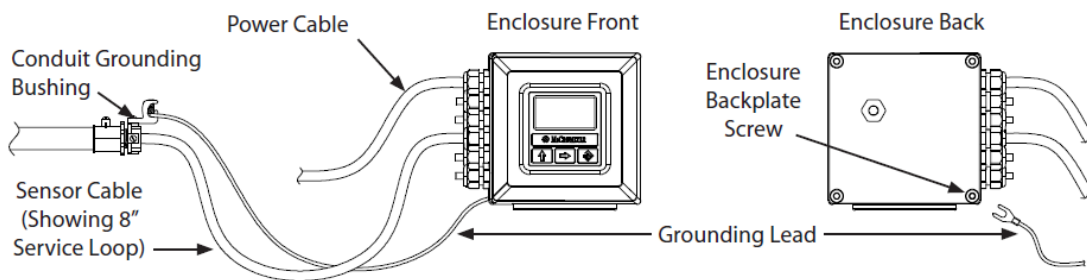

IMPORTANT: All cables must have a minimum 8" service loop.

Figure 15: Cable Installation

8.3 Pulling Sensor Cable through Electrical Conduit

It is very important to protect the end of the sensor cable when pulling it through a conduit. Water can accumulate in low portions of conduit. Always use the factory supplied cable cover, or similar method, to seal the end of the cable against water when pulling the cable through conduit. This will ensure proper operation of the meter.

Pulling the Sensor Cable:

1. Tie a rope or cable-snake securely around the middle of the cable cover.
2. Carefully pull the rope or snake until the sensor cable end clears the conduit.
3. Bring the cable end to the converter location. If necessary, secure the cable so that it does not fall back through the conduit.
4. Remove the cable cover by pulling the rip wire. The cable cover will tear off (discard the cover).

i **CAUTION:** Do not cut the cable cover off. Doing so may damage the sensor cable and adversely effect the calibration of the meter.

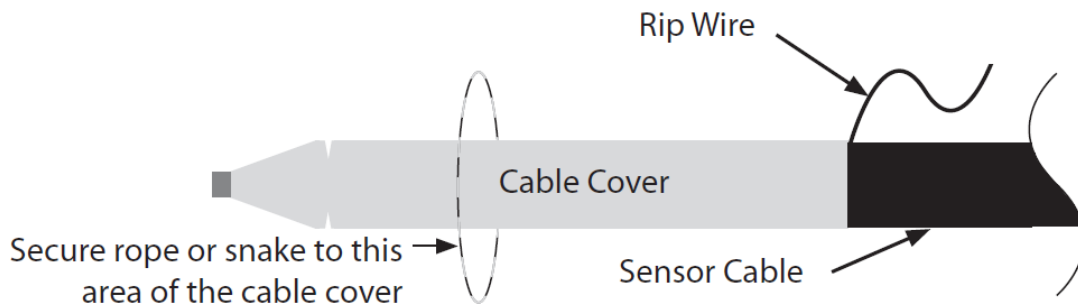

Figure 16: Cable Cover

8.4 Sensor Cable

SPI sensor cable is supplied standard as a 20 ft length.

Never under any circumstance cut the sensor cable. Specify length of cable needed when ordering the valve or have a Singer trained professional install the cable correctly.

The length of sensor cable should to be minimized to ensure the best quality signal. If a long cable is needed for a specific application, install the converter near the SPI-MV valve and run a 4-20mA signal to the end location

8.5 Sensor Electrical Cable Connections

All electrical cables enter the converter through compression fittings located on the side of the converter. Ensure that all compression glands are properly tightened and all unused fittings are plugged so the case remains sealed.

Always disconnect the power cord before attempting any electrical connections

8.5.1 Terminal Board

All connections are made on the terminal board. To access the terminal board, loosen the four screws on the back of the converter to remove the rear cover.

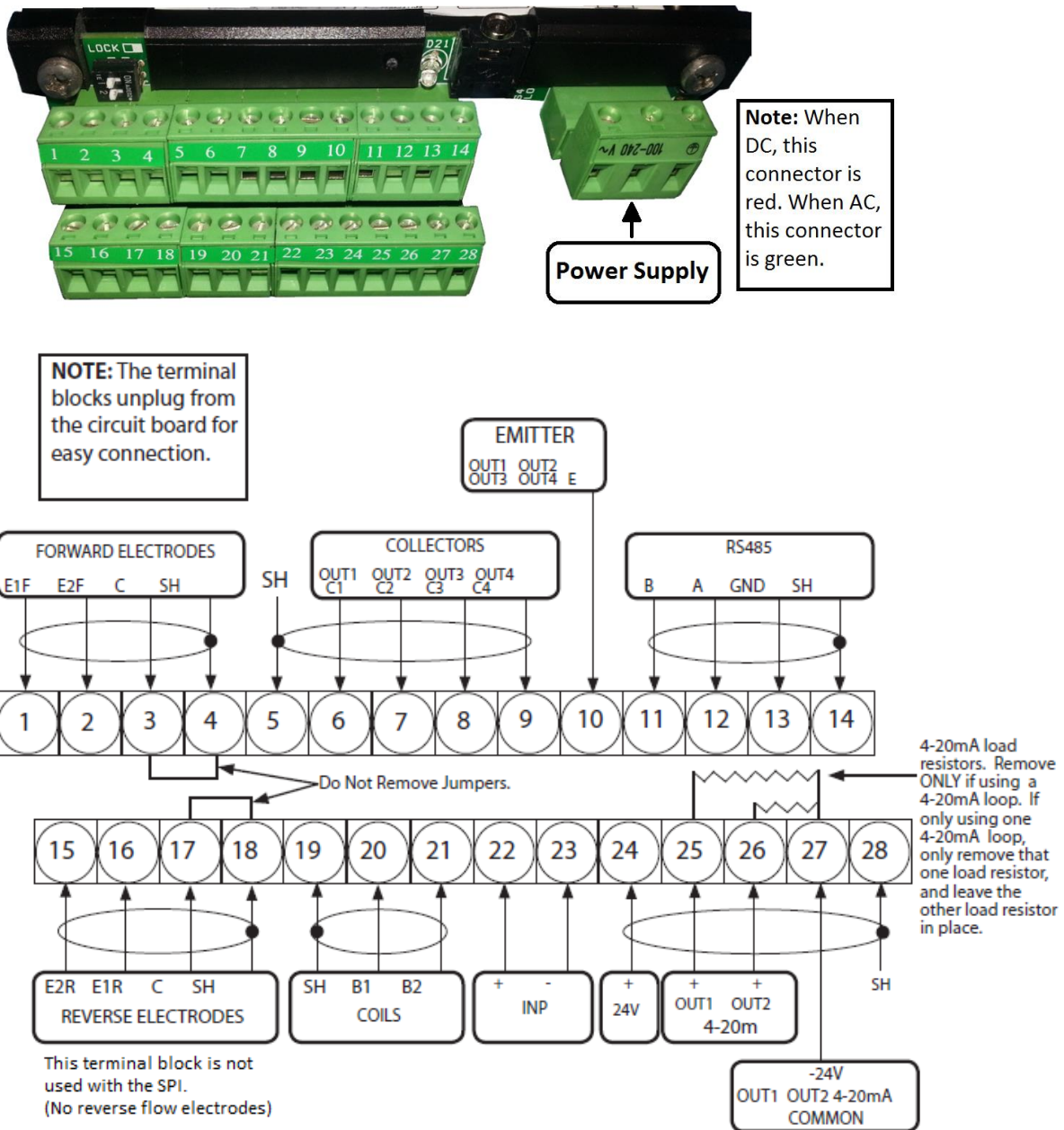

Figure 17: Terminal Board Layout

8.5.2 Sensor Wiring

Table 1: Terminal Block Assignments

Terminal	Wire Color	Connected To
#1	Blue	Sensing electrode
#2	White	Sensing electrode
#3	Black	Reference ground
#19	Black	Magnet shield / overall cable shield
#20	Red	Coil
#21	Yellow	Coil

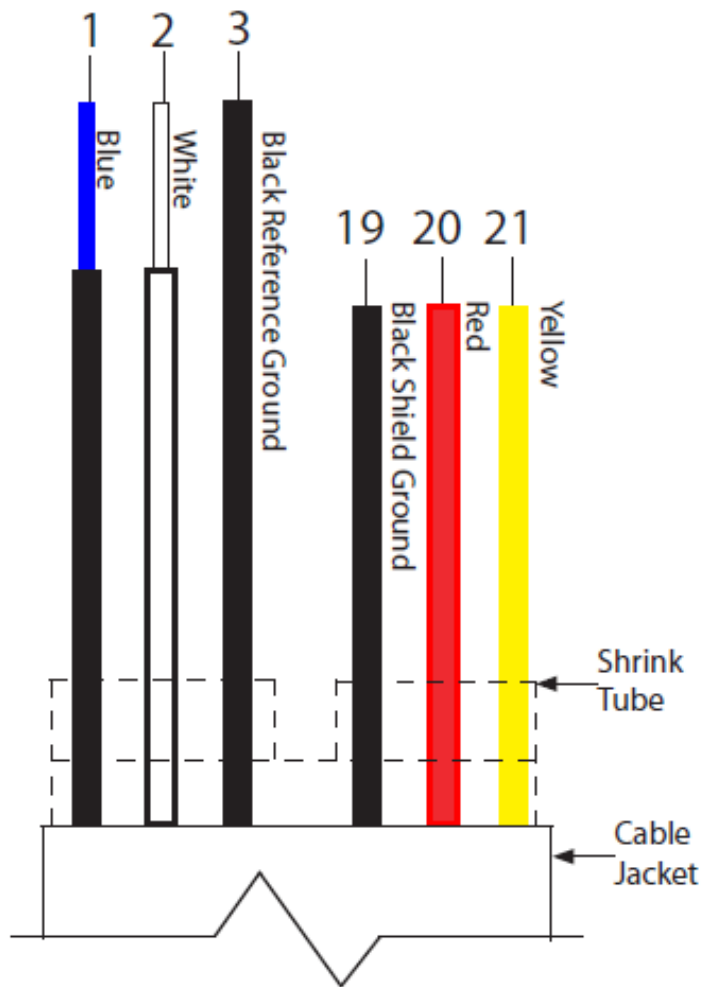

Figure 18: Wire Labeling



Figure 19: SPI Cable Wires

8.5.3 4-20mA Hook-Up

Two isolated 4-20mA current loops are used to output flow data to external devices. Maximum load impedance is 1,000Ω, and the maximum voltage without load is 27VDC. The converter has the capability to detect a loss of load on this output. To disable this function set the value “mA Val. Fault” under the ALARMS menu to zero. A graphical example of the usage of the current loop with external device is shown below:

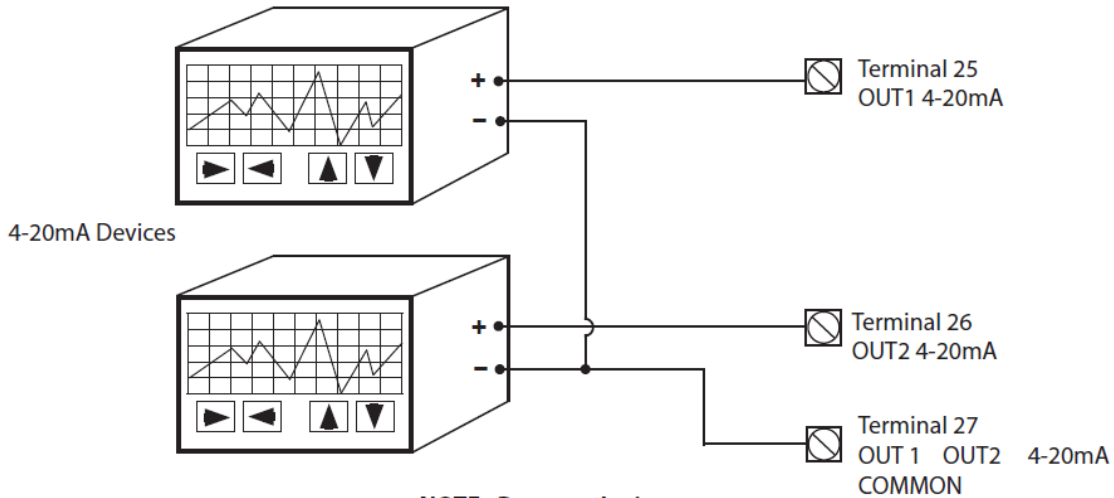

NOTE: Remove the jumper from terminals 25 & 27 and/or 26 & 27 before attaching 4-20mA cables.

Figure 20: 4-20mA Hook-Up

If the external device requires a voltage input, a precision resistor placed across the input terminals of the external device will change the current to voltage. Calculate the required resistor using Ohm’s law ($V = I \times R$). For example, a 250Ω resistor will provide an input voltage of one to five volts with the transmitter range being set from 4mA to 20mA. An additional 4 to 20mA loop output is available.

IMPORTANT

 The converter powers the 4-20mA loops. Do not use external power for the 4-20mA loop as it may cause permanent damage to the converter.

8.5.4 Opto-Isolated Pulse Output Hook-Up

The four pulse outputs are open collector transistor outputs used for communicating with or activating external devices.

Output Specifications:

- Opto-isolated output with collector and emitter terminals floating and freely connectable
- Max switching voltage: 40 VDC
- Max switching current: 100mA
- Max saturation voltage between collector and emitter: 1.2V@100mA
- Max switching frequency (load on the collector or emitter, $R_L=470\Omega$, $V_{OUT}=24VDC$): 1250Hz
- Max reverse current bearable on the input during an accidental polarity reversion (VEC): 100mA
- Insulation from other secondary circuits: 500 V

See Table 2 and Table 3 in section 9.10 *Menu 6 - Outputs* for available output functions.

Figure 21 below shows the recommended wiring for a pulse output. The connection to output 1 is shown. For other outputs, replace terminal 6 with the terminal corresponding to the desired output (see Figure 17).

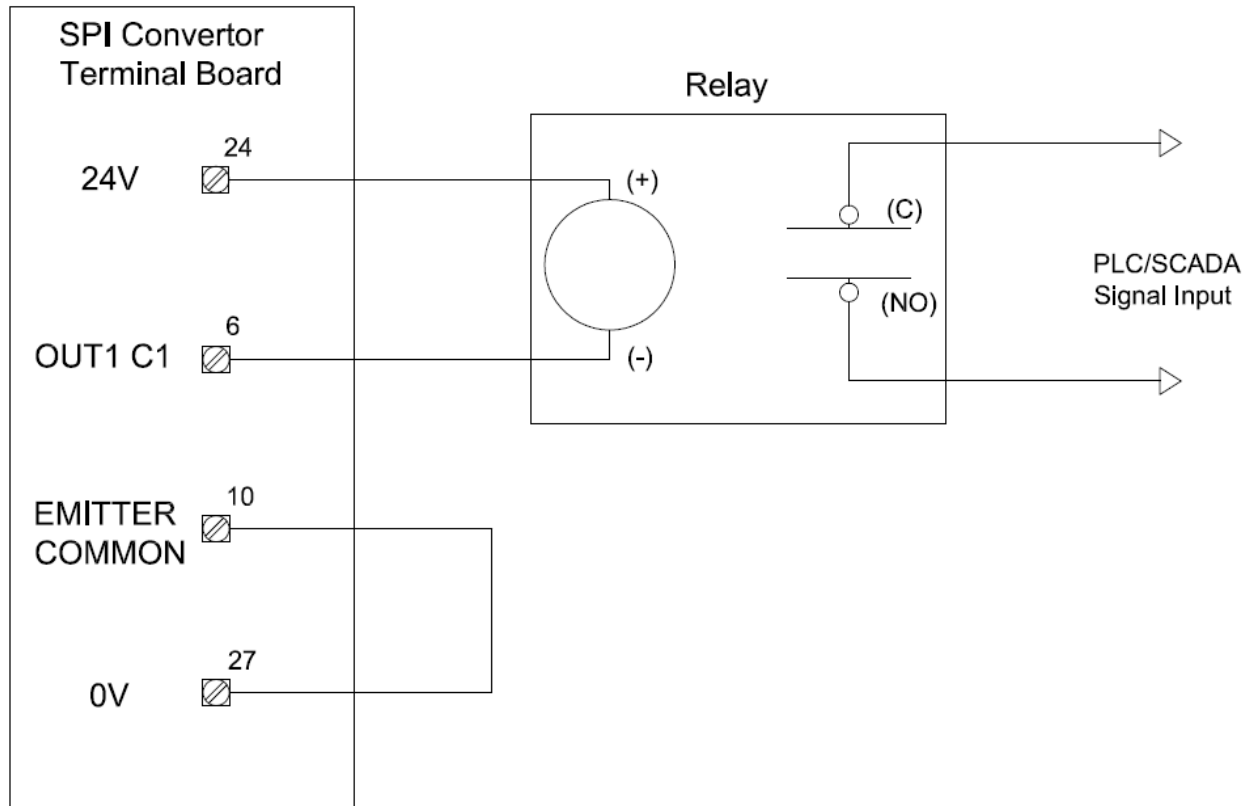



Figure 21: Opto-Isolated Pulse Output 1 Connection via Relay

8.5.5 Converter Power Hook-Up



WARNING!
Hazardous supply voltage can shock, burn, or cause death.

The power supply line must be equipped with external surge protection for current overload (fuse or circuit breaker with limiting capacity not greater than 10A). It must be easily accessible for the operator and clearly identified. Power connection is made using the power terminal block on the upper right side of the terminal board.

NOTE: The terminal block unplugs from the circuit board for easy connection. Connect earth ground to the protective grounding terminal before making other connections. The power supply of a standard converter is 90-265VAC, 44-66Hz at maximum 20W. DC converter is available as an option.

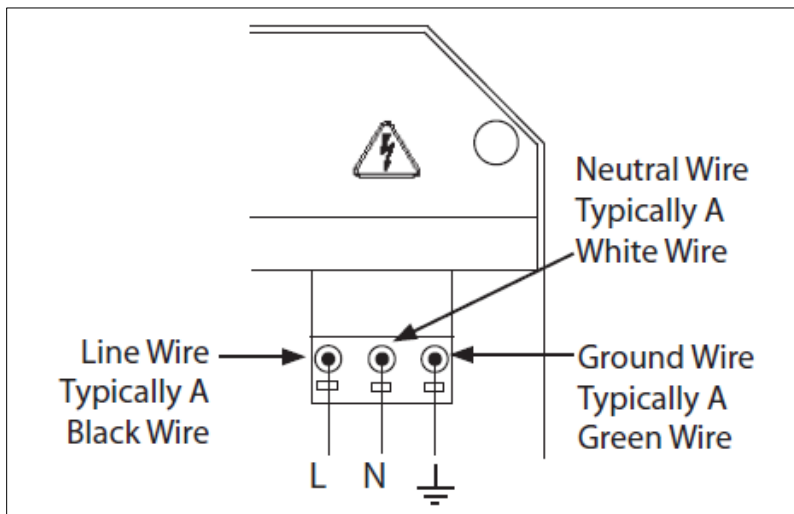

Figure 22: AC Power Wiring

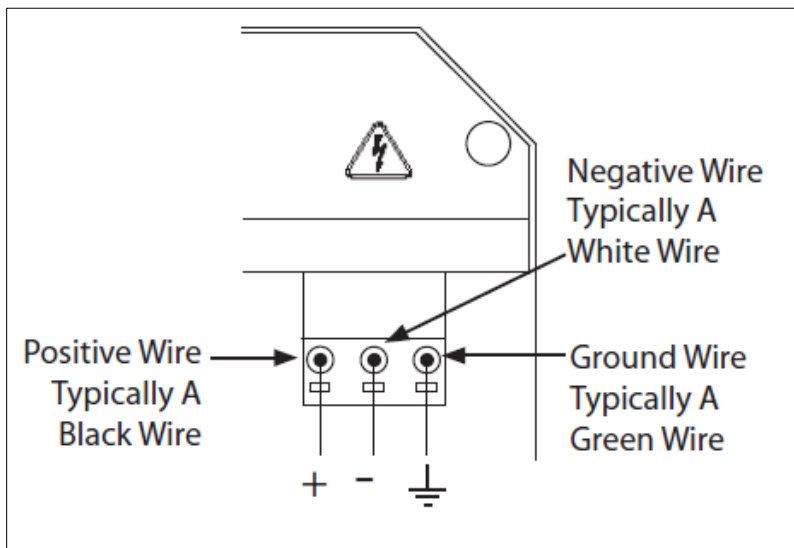

Figure 23: DC Power Wiring

8.5.6 Converter Start-Up

Before starting up the converter please verify the following:

- Power supply voltage must correspond to that specified on the data plate (located on the side of the converter)
- Electric connections must be wired as described in this manual
- Ground connections must be properly installed

When the converter is powered it initiates a verification cycle of the converter. During the verification cycle the converter displays an incrementing diagnostic number from 0 through 90. When the diagnostic is complete, if an error is found, an error code will be displayed. A text message will also be displayed on the alarm screen. If an error is found, contact factory for support.

8.6 Grounding

One of the most important installation details for magnetic flowmeters, in general, is proper process ground. A proper ground ensures that the fluid and sensor are at the same potential so that only the induced flow signal is measured. The most stable ground reference is the earth ground itself. By connecting the fluid, sensor, and converter to a stable and noise free reference point, the SPI will offer the best performance.

Note: The AC supply ground may not provide adequate grounding. In some cases, an AC ground can induce noise to the low voltage signals generated by the magnetic flowmeter. It is recommended to wire the ground connection to a separate low impedance earth ground or a dedicated instrumentation ground.

These are the recommended grounding arrangements:

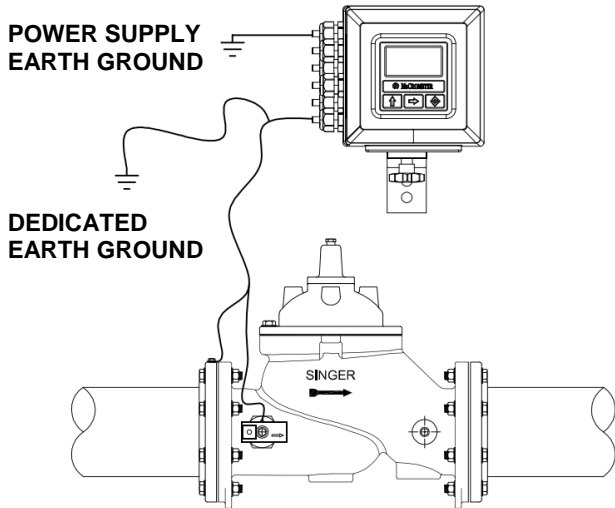

Figure 24: Grounding for conductive pipe or conductive-lined pipe

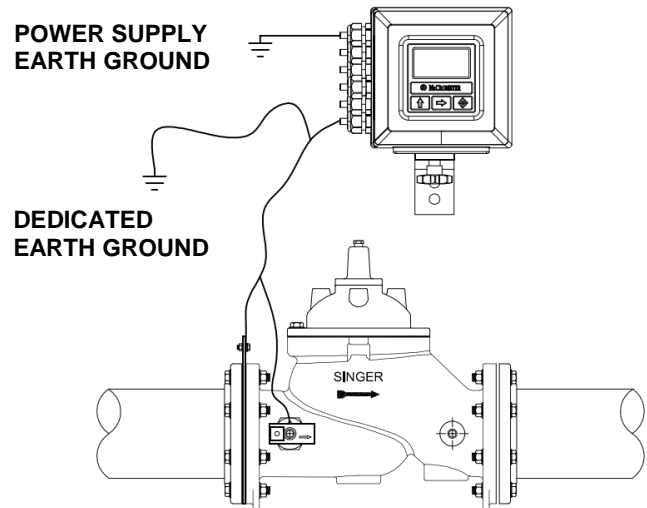

Figure 25: Grounding with grounding rings

See Figure 26, Figure 27, and Figure 28 below for examples of proper converter and probe grounding.



Figure 26: Converter & probe with ground wiring



Figure 27: SPI Converter Grounding

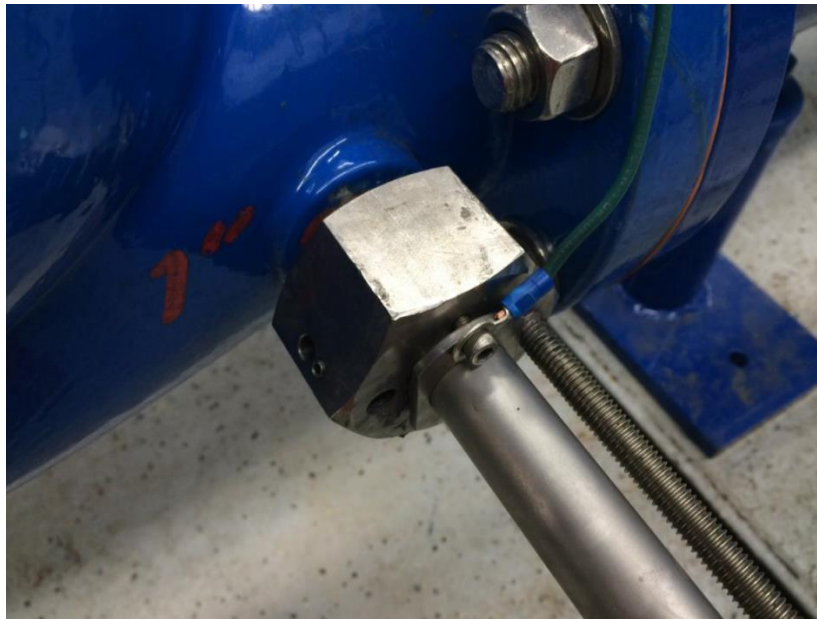
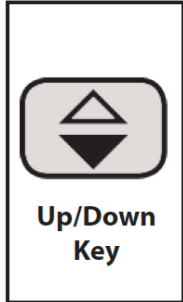

Figure 28: SPI Probe Grounding

9 Menu Navigation

To navigate through the menus on the converter, the keys on the keypad use the following conventions:

Key:



Function:

UP/DOWN KEY (for moving cursor up or down)

SHORT PRESSING (< 1 SECOND):

Moves the cursor up to the previous subject on the menu
Increases the numeric figure of the parameter highlighted by the cursor

LONG PRESSING (> 1 SECOND):

Moves the cursor down to the next subject on the menu
Decreases the numeric figure of the parameter highlighted by the cursor



RIGHT/LEFT KEY (for moving cursor right or left)

SHORT PRESSING (< 1 SECOND):

Moves the cursor to the right on the input field
Moves the cursor to the following subject of the menu
Changes the display of the process data

LONG PRESSING (> 1 SECOND):

Moves the cursor to the left on the input field
Moves the cursor to the previous subject on the menu

Note: Push and hold for eight seconds to cycle through contrast settings.



ENTER/ESC KEY (for changing settings)

SHORT PRESSING (< 1 SECOND):

Opens the Quick Start menu for the instrument configuration
Enters the selected function
Cancels the selected function under progress

LONG PRESSING (> 1 SECOND):

Confirms the selected function
Leaves the current menu

9.1 Front Panel Display

Short-press the Right/Left arrow key to view different visualization screens.

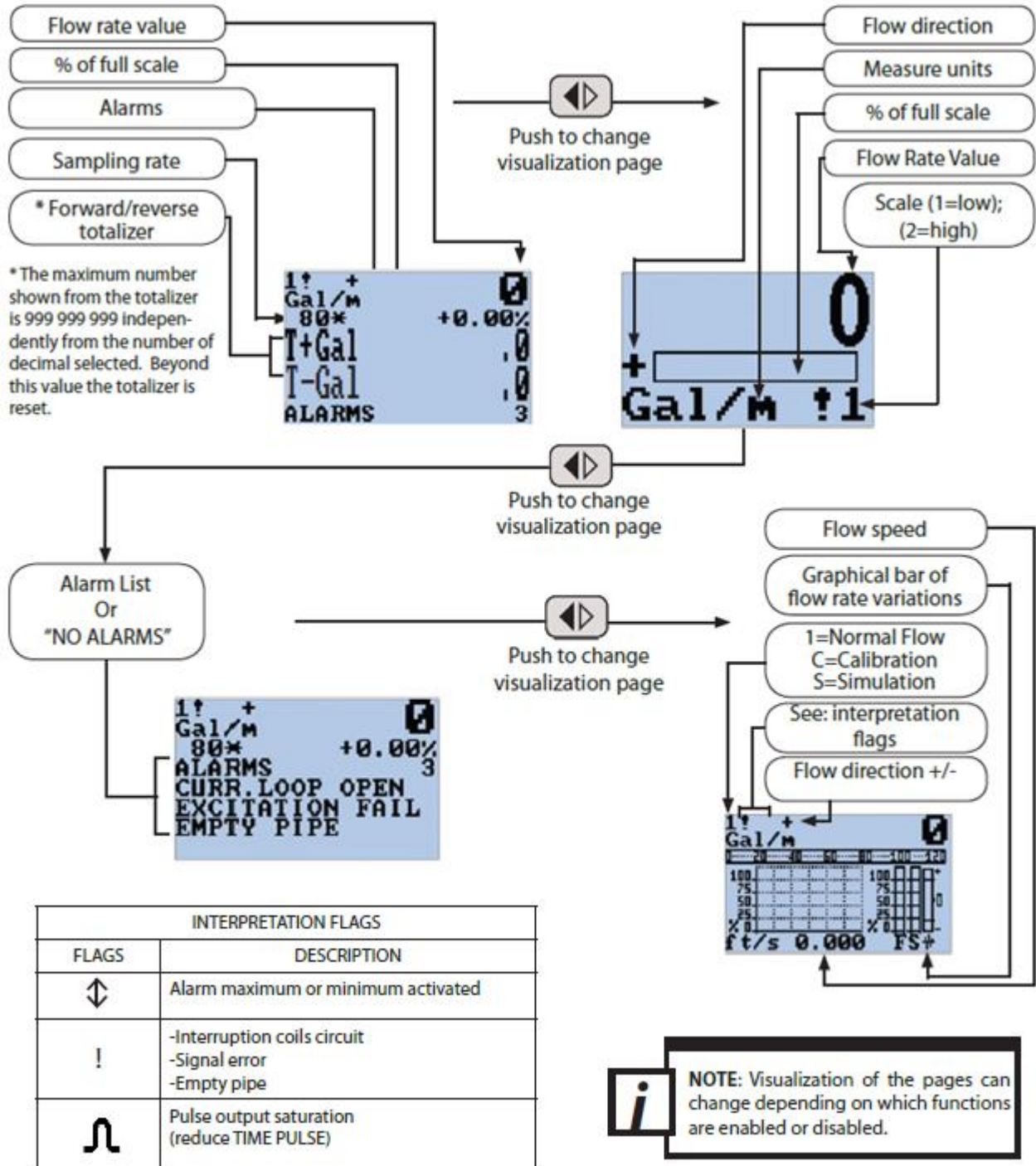



Figure 29: Front Panel Display

9.1.1 Factory Pre-Setting

The converter is delivered with “Quick start menu” enabled and with **passcode L2 = 000002**. Press the Enter/Esc key to access the Quick start menu.

	<p>ATTENTION! It is very important to record any customized code as it CANNOT be retrieved if it is lost!</p>
---	--

9.2 SPI Menu Structure

The following is the menu structure for the SPI converter.
 Main menu access requires the **L2 passcode 000002**.

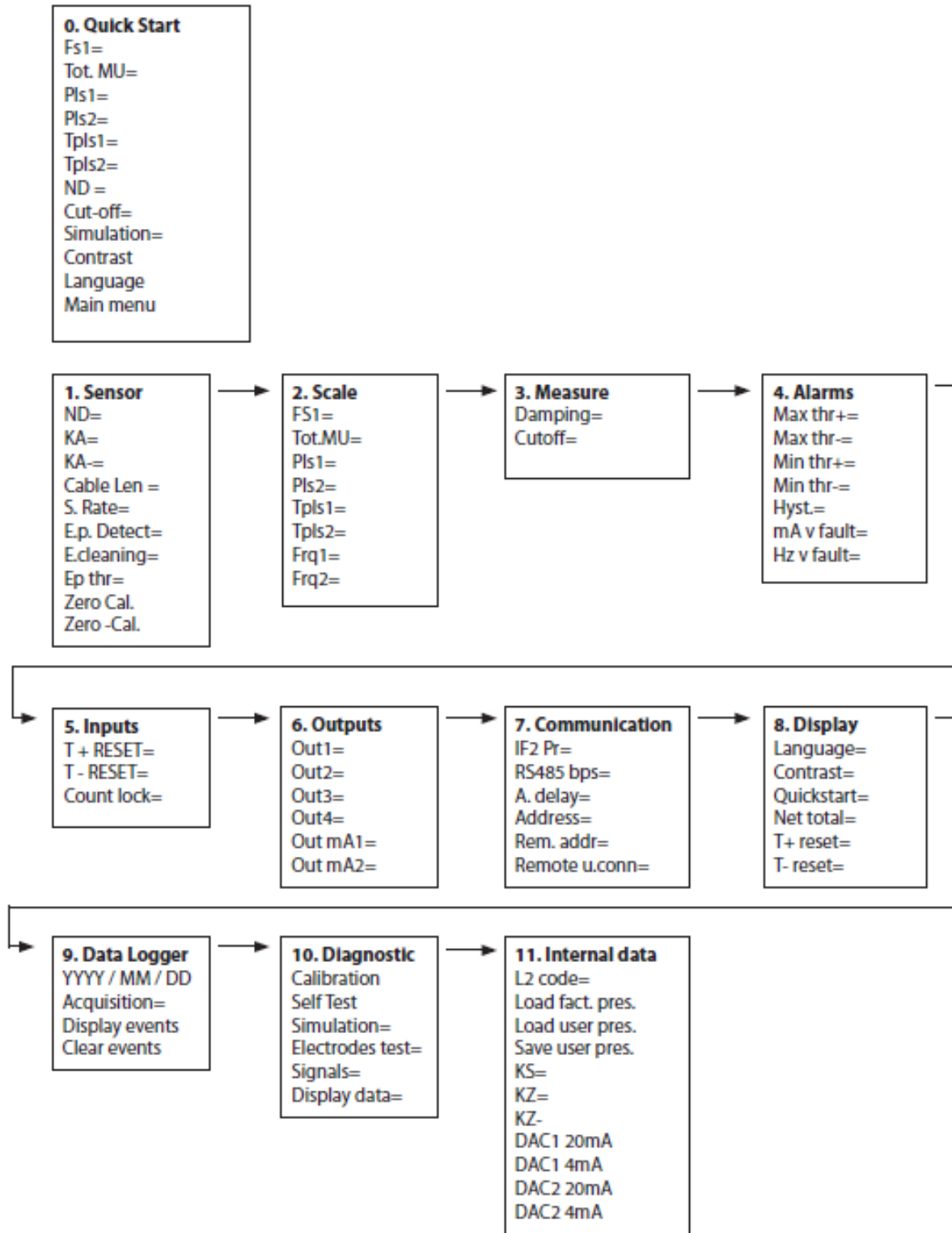

Figure 30: Menu Structure

9.3 Programming Example

The steps below demonstrate how to modify the full scale value from 4 Gal/m to 5 Gal/m from the "Quick start menu".

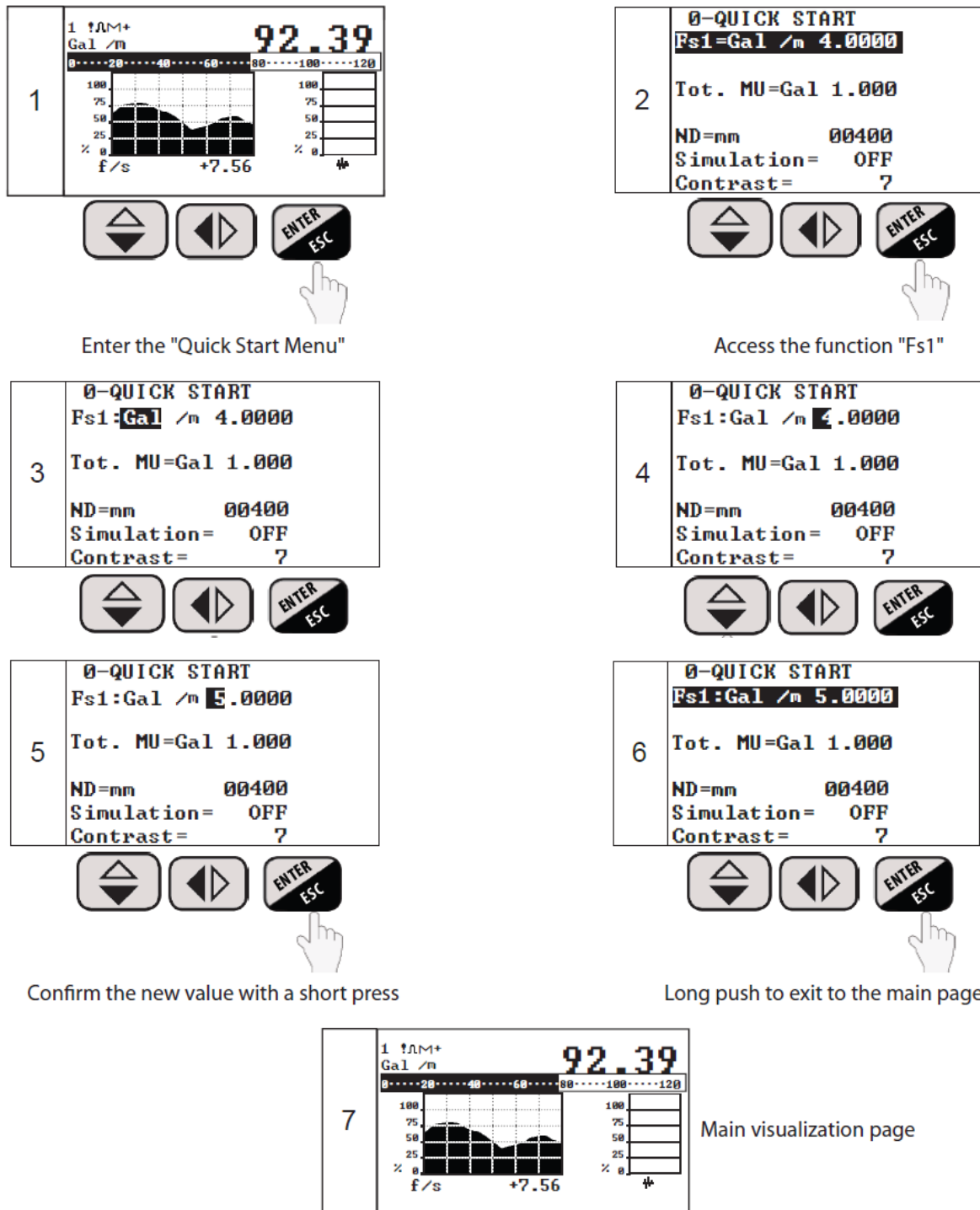

Figure 31: Programming Example: Changing Full Scale Value

9.4 Quick Start Menu

The functions in the Quick Start menu and the Main menu are explained below. Please note that some functions are only displayed if other functions are enabled or with the insertion of additional modules. Access the Quick Start Menu by pressing the Enter/Esc key from the visualization page.

NOTE: If the Quick Start Menu is disabled:

From the flow visualization, press the Enter/Esc key. The L2 passcode screen will appear. Enter the **passcode of 000002**, then press the Enter/Esc key to access the main menu. When the Quick Start Menu is enabled, you can enter the Main menu from the “Quick start menu”.

9.4.1 Fs1

The units of measure and full scale range of the meter that defines the 20mA output. Generally this value is set 10% over the anticipated max flow. US standard & metric units are selectable from this menu. See *Appendix 12.3 Units of Measure* for available units of measure.

To change the full scale value, highlight the “Fs1” menu and press the Enter/Esc key. The unit will highlight. Press the Up/Down key to scroll thru the different available units.



Once you have selected the desired unit, press the Right/Left key twice to highlight the lower case letter that represents the time unit. Again press the Up/Down key to scroll thru the available time units. Once the unit of measure and time unit have been selected, press the Right/Left key to select the numeric value. Press the Up/Down key to set the digit and Right/Left key to move to the next digit. Once the desired value is entered, press the Enter/Esc key to exit/highlight the menu.



NOTE: If a unit you are looking for is not in the current list, press the Right/Left key and scroll to the “/” between the unit of measure and time unit selections and press the Up/Down key to switch between U.S. Standard and Metric units.

Once the desired value is entered, quick push the Enter/Esc key to highlight the entire line and then long push Enter/Esc to exit back to the display.



9.4.2 Tot. MU

The totalizer unit/multiplier and decimal resolution. See *Appendix 12.3 Units of Measure* for available units of measure. To change the totalizer unit/multiplier, select the Tot. MU menu and press the Enter/Esc key. This will highlight the unit/multiplier.



Press the Up/Down key to scroll through the available units until the desired unit has been selected.

NOTE: The totalizer multiplier is built into the unit of measure, so for gallons multiplied by 1000, select KGal.

Once the unit of measure is selected, press the Right/Left key twice to highlight the numeric value to the right. Then press the Up/Down key to change the decimal resolution displayed for this totalizer. Changing the decimal resolution will not change the multiplier. The available selections are 00001, 001.0, 01.00, and 1.000.



NOTE: If the desired unit of measure is not in the current list, press the Right/Left key and scroll to the blank space between the unit/multiplier and the numeric decimal resolution selection and press the Up/Down key to switch between U.S. Standard and Metric units.



9.4.3 Pls1

The pulse increment value and unit of measure for the pulse output 1. This option is only available when “out1” in “Menu 6 – Outputs” (section 9.10.1) is set to #1 IMP+.

9.4.4 Pls2

The pulse increment value and unit of measure for the pulse output 2. This option is only available when “out2” in “Menu 6 – Outputs” (section 9.10.2) is set to #2 IMP+.

9.4.5 Tpls1

Duration of the pulse output 1 expressed in milliseconds. The pulse duration can be set from .4 to 9999.99. This option is only available when “out1” in “Menu 6 – Outputs” (section 9.10.1) is set to #1 IMP+. Factory set to 50ms, which should not need to be changed.

9.4.6 Tpls2

Duration of the pulse output 2 expressed in milliseconds. The pulse duration can be set from .4 to 9999.99. This option is only available when “out2” in “Menu 6 – Outputs” (section 9.10.2) is set to #2 IMP+. Factory set to 50ms, which should not need to be changed.

9.4.7 ND

Inside Pipe Diameter in millimeters. This is factory set to match the measured ID of the Singer Valve it is calibrated for. Should not be changed from factory setting.

9.4.8 Cutoff

Cut off point below which all flow is reported as zero. This value is set as a percentage of the full scale. This setting ensures no noise will be reported when zero flow is present.

NOTE: When running a Zero Calibration (section 9.5.8), ensure the cutoff value is set to 2.0.

9.4.9 Simulation

Simulation Enable. Setting this menu to ON will generate an internal signal that simulates flow and allows the outputs and all connected instruments to be tested. After simulation is set to ON, the flow can be set to a percentage based on the current FS1 setting -125% to 125%.

To enable the simulation function, use the Right/Left key to highlight the Simulation menu and press the Enter/ Esc key. Enter **L2 passcode 000002**.



The simulation function can now be toggled from OFF to ON by using the Up/Down key. Select ON to turn on the Simulation mode and press the Enter/ Esc key.



Press and hold the Enter/Esc key to exit back to the visualization page.

NOTE: There will now be an “S” in the upper left corner; this indicates the simulation mode is active.

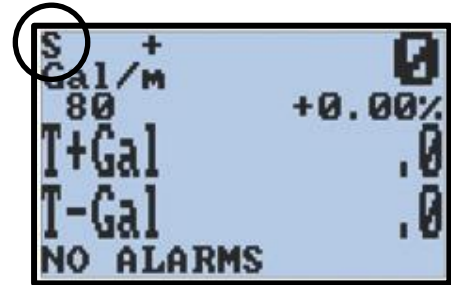

Press the Enter/Esc key. This will bring up the flow simulation set up screen. Use the Right/Left key and the Up/ Down key to enter in the flow rate percentage value for the simulation. Press the Enter/Esc key to enter that value.

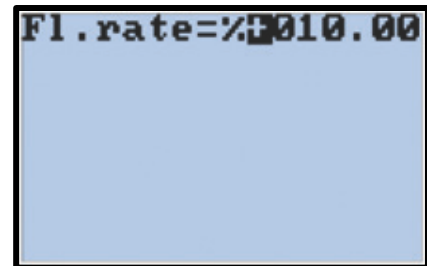

The converter will start to read flow. It may take a few seconds for the readings to appear. Repeat the above steps as needed to observe the different flow rates desired.

To exit out of simulation mode, re-enter into the simulation set up screen (see above) and then press and hold the Enter/Esc key. This will exit out to the visualization screen, and the “S” in the upper left corner of the screen will return to a “1”.

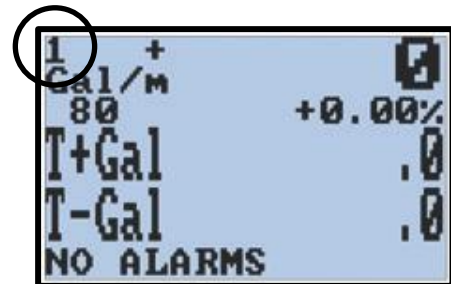

9.4.10 Contrast

Display contrast set point. The display contrast can be changed to make the display appear more visible based on the users preference. This menu can be set 0 to 15 with the change only taking affect once the menu selection has been selected by pressing the enter key.

NOTE: If set to high or too low the display can become unreadable. If this happens wait 60 seconds from the time of the last button push for the display to time out to the visualization page. From the visualization page press and hold the Right/Left button. The display will cycle through a different preset display contrast settings every 8 seconds. Release the button once you have found a setting that can be read.

9.4.11 Language

Choose a language to display the converter menus in. Available options are EN = English, IT = Italian, FR = French, SP = Spanish and DE = German.

9.4.12 Main menu

Allows access to the main menu which contains advanced configuration menus. Enter the **L2 Passcode 00002**.

9.5 Menu 1- Sensor

9.5.1 ND Inside Pipe Diameter

Inside Pipe Diameter in millimeters. This is factory set to match the measured ID of the Singer Valve it is calibrated for. Should not be changed from factory setting.

9.5.2 KA

Factory calibrated gain for the forward flow. Do not change the value.

9.5.3 Cable length

Cable length set in increments of 10 meters, rounded to the nearest 10 meter increment.

9.5.4 S. rate

Factory calibrated frequency sampling rate. Do not change the value.

9.5.5 E.P. Detect

Set the empty pipe alarm to on or off. Factory default = ON.

NOTE: Setting the E.P. Detect to "off" will disable an alarm when an empty pipe is present. When the pipe is empty, sensor may display environmental/electrical noise as flow.

9.5.6 E.I. cleaning

Factory set value. Do not change the value.

9.5.7 E.p. thr

Empty Pipe Threshold is the numeric value selected during the Empty Pipe Calibration function. In some cases it may be required to manually adjust this value to be more compatible with an installation. For assistance adjusting this value contact Technical Support. Available settings are from 0 – 250 with a factory default of 195.

NOTE: If there is a high level of noise, the E.P Alarm may be active even though the pipe is full of water. Ensure grounding is correct to eliminate as much noise as possible.

9.5.8 Zero Cal

Zero point calibration function for the forward flow. To perform the Zero point Calibration, select the Zero Cal. Menu and press the Enter/Esc key. This will enable the zeroing function. You will see a percent value that is positive or negative.

i **IMPORTANT** - The water must be perfectly still before starting the Zero Cal process or an offset will be introduced into the flow report.

```

1-SENSOR
Cable len.=m 010
S.rate=Hz 20
E.P.detect= ON
E.I.signal= 000
E.p.thr.= 250
Zero cal.
Zero- cal.
    
```

```

1-SENSOR
Cable len.=m 010
S.rate=Hz 20
E.P.detect= ON
E.I.signal= 000
E.p.thr.= 250
Measuring... 685
Zero- cal.
    
```

Now press and hold the Up/Down button and release when the message "Measuring. . ." appears. The converter counts up from zero to 1,000, after which the zero point is set. The new value should be less than before the autozero was performed. If not, then verify that there is no flow in the pipe and repeat.

```

1-SENSOR
Cable len.=m 010
S.rate=Hz 20
E.P.detect= ON
E.I.signal= 000
E.p.thr.= 250
% +0.0000
Zero- cal.
    
```

Note: If the zero cal starts measuring and jumps out, there is too much noise to complete the zero cal. Ensure grounding is correct to eliminate as much noise as possible.

9.6 Menu 2 – Scales

9.6.1 Fs1

The units of measure and full scale range of the meter that defines the 20mA output. Generally this value is set 10% over the anticipated max flow. US standard & metric units are selectable from this menu. See *Appendix 12.3 Units of Measure* for available units of measure.

To change the full scale value, highlight the "Fs1" menu and press the Enter/Esc key. The unit will highlight. Press the Up/Down key to scroll thru the different available units.

```

2-SCALES
Fs1: gal/m 006000
Tot.MU=KGL 001.0
Pls1=KGL 1.00000
Tpls1=ms 0050.00
    
```

```

2-SCALES
Fs1: gal/m 006000
Tot.MU=KGL 001.0
Pls1=KGL 1.00000
Tpls1=ms 0050.00
    
```

Once you have selected the desired unit, press the Right/Left key twice to highlight the lower case letter that represents the time unit. Again press the Up/Down key to scroll thru the available time units. Once the unit of measure and time unit have been selected, press the Right/Left key to select the numeric value. Press the Up/ Down key to set the digit and Right/Left key to move to the next digit. Once the desired value is entered, press the Enter/Esc key to exit/highlight the menu.

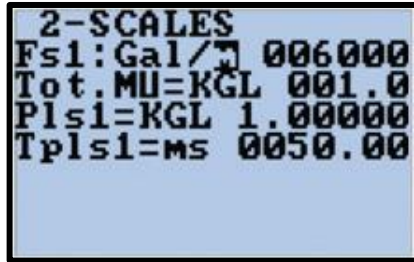

NOTE: If a unit you are looking for is not in the current list, press the Right/Left key and scroll to the “/” between the unit of measure and time unit selections and press the Up/Down key to switch between U.S. Standard and Metric units.



Once the desired value is entered, quick push the Enter/Esc key to highlight the entire line and then long push Enter/Esc to exit back to the display.

9.6.2 Tot. MU

The totalizer unit/multiplier and decimal resolution. See *Appendix 12.3 Units of Measure* for available units of measure. To change the totalizer unit/multiplier, select the Tot. MU menu and press the Enter/Esc key. This will highlight the unit/multiplier.

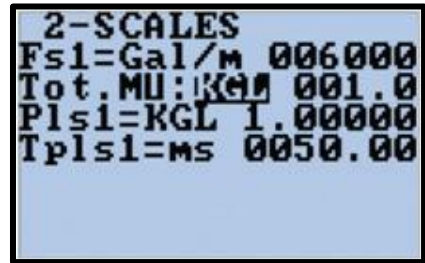
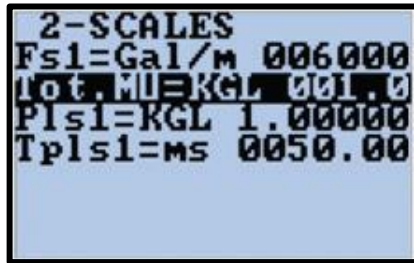

Press the Up/Down key to scroll through the available units until the desired unit has been selected.

NOTE: The totalizer multiplier is built into the unit of measure, so for gallons multiplied by 1000, select KGal.

Once the unit of measure is selected, press the Right/Left key twice to highlight the numeric value to the right. Then press the Up/Down key to change the decimal resolution displayed for this totalizer. Changing the decimal resolution will not change the multiplier. The available selections are 00001, 001.0, 01.00, and 1.000.



NOTE: If the desired unit of measure is not in the current list, press the Right/Left key and scroll to the blank space between the unit/multiplier and the numeric decimal resolution selection and press the Up/Down key to switch between U.S. Standard and Metric units.

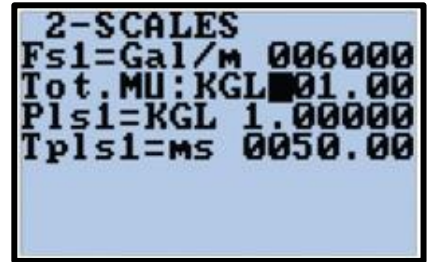

```
2-SCALES
Fs1=Gal/m 006000
Tot. MU: KGL 01.00
Pls1=KGL 1.00000
Tpls1=ms 0050.00
```

9.6.3 Pls1

The pulse increment value and unit of measure for the pulse output 1. This option is only available when “out1” in “Menu 6 – Outputs” (section 9.10.1) is set to #1 IMP+.

9.6.4 Pls2

The pulse increment value and unit of measure for the pulse output 2. This option is only available when “out2” in “Menu 6 – Outputs” (section 9.10.2) is set to #2 IMP+.

9.6.5 Tpls1

Duration of the pulse output 1 expressed in milliseconds. The pulse duration can be set from .4 to 9999.99. This option is only available when “out1” in “Menu 6 – Outputs” (section 9.10.1) is set to #1 IMP+. Factory set to 50ms, which should not need to be changed.

9.6.6 Tpls2

Duration of the pulse output 2 expressed in milliseconds. The pulse duration can be set from .4 to 9999.99. This option is only available when “out2” in “Menu 6 – Outputs” (section 9.10.2) is set to #2 IMP+. Factory set to 50ms, which should not need to be changed.

9.6.7 Frq1

Full scale frequency value for output 1. This option is only available when out1 in *Menu 6 - Outputs* is set to #1 FREQ+. The value is set in hertz between 1.0 to 1,000.0.

NOTE: When the high frequency output is present the maximum value may go up to 10,000.0 Hz.

9.6.8 Frq2

Full scale frequency value for output 1. This option is only available when out2 in *Menu 6 - Outputs* is set to #2 FREQ+. The value is set in hertz between 1.0 to 1,000.0.

IMPORTANT



The converter cannot detect the type of device it is connected to so it is up to the user to verify the setting is compatible with the external device receiving the pulse. Incorrect settings can damage the receiving device. See section 8.10, "Menu 6 - Outputs", for output specifications.

9.7 Menu 3 - Measure

9.7.1 AC Filter

This filter deals with AC noise from the power source, poor earth grounding and electrical noise on the fluid column.

NOTE: This is a factory set filter. Changing this filter will have a direct effect on meter response time and should only be adjusted with the assistance of Technical Support.

9.7.2 Damping

This sets the dampening or filter setting for the meter. This setting can be changed to make the meter more or less responsive and/or stable. The available dampening filter values range from 0 (no dampening or dampening OFF) to a maximum dampening of 1,000 seconds. There are also some specialized "SMART" settings. The "SMART" settings are not intended for use with the SPI flow meter and should not be selected. With the dampening turned off the converter responds immediately to any change in flow, but this can result in a noisy output. With the dampening set to values between 0.2 seconds and 1000 seconds the converter buffers and averages flow data over the period of time specified. Larger values tend to provide a quieter and more stable output but will respond more sluggishly to large changes or transitions in flow rate. Typically, the damping is set to 10-20 seconds.

NOTE: This is a factory set filter. Changing this filter will have a direct effect on meter response time and should only be adjusted with the assistance of Technical Support.

9.7.3 Cut-off

Cut off point which all flow is reported as zero. This value is set as a percentage of the full scale.

9.8 Menu 4 - Alarms

9.8.1 Max Thr +

Maximum flow threshold, forward flow. This is the set point to trigger a high flow alarm set as a percentage of full scale. This function is disabled when set to zero.

9.8.2 Max Thr –

Maximum flow threshold, reverse flow. This is the set point to trigger a high flow alarm set as a percentage of full scale. This function is disabled when set to zero.

9.8.3 Min thr +

Minimum flow threshold, forward flow. This is the set point to trigger a low flow alarm set as a percentage of full scale. This function is disabled when set to zero.

9.8.4 Min thr –

Minimum flow threshold, reverse flow. This is the set point to trigger a high flow alarm set as a percentage of full scale. This function is disabled when set to zero.

9.8.5 Hyst

Set 0-25%. This sets the lag in response based on a percentage of the full scale. Example if the alarm triggers at 100% and the hysteresis is set to 2% then once triggered the current rate must change beyond 2% to exit out of the current alarm state. This setting applies to all alarms.

9.8.6 mA v. fault

Current output value during alarm events set as a percentage 0-120% of the current output range. The current range 0/4mA to 20/22mA is set in *Menu 6 - Outputs*. For example, if an empty pipe alarm is present and the mA v. fault value is set to 10% and the current scaling is set 4 to 20mA, then the current output would send a 2mA signal until the empty pipe alarm is cleared. This function is disabled when set to zero.

9.8.7 Hz v. fault

Frequency output value during alarm events set as a percentage 0-125% of the frq1/frq2 range. For example, if an empty pipe alarm is present and the Hz v. fault value is set to 110% and the Frq1 scaling is 100 Hz, then the frequency output on channel 1 would send a 110 Hz signal until the empty pipe alarm is cleared. This function is disabled when set to zero.

9.9 Menu 5 - Inputs

9.9.1 T+ reset

Positive Totalizer Reset Enable. Set by turning on or off. This allows for the positive total totalizer to be reset through the input.

9.9.2 T- reset

Negative Totalizer Reset Enable. Set by turning on or off. This allows for the negative total totalizer to be reset through the input.

9.9.3 Puls.reset

Pulse Output Reset Enable. Set by turning on or off. This allows for the totalized pulses to be reset through the input.

9.9.4 Count lock

Totalizer Count Lock Input Enable, Set by turning on or off. This allows for the totalizers to be locked (frozen) when the input is active.

9.10 Menu 6 - Outputs

9.10.1 Out 1

Transistor output channel 1. See Table 2 and Table 3 for available settings.

9.10.2 Out 2

Transistor output channel 2. See Table 2 and Table 3 for available settings.

9.10.3 Out 3

Transistor output channel 3. See Table 3 for available settings.

9.10.4 Out 4

Transistor output channel 4. See Table 3 for available settings.

9.10.5 Out mA1

Current output channel 1. See Table 4 for available settings.

9.10.6 Out mA2

Current output channel 2. See Table 4 for available settings.

Table 2: Outputs available for open collector transistor outputs #1 & #2 only:

Function Symbol	Function Explanation
#1 IMP+	Pulse on output 1 for forward flow rate. Only assignable to channel 1. This option will trigger 1 pulse per totalizer count for the forward flow totalizer.
#1 IMP-	Pulse on output 1 for reverse flow rate. Only assignable to channel 1. This option will trigger 1 pulse per totalizer count for the reverse flow totalizer.
#1 IMP	Pulse on output 1 for forward and reverse flow rate. Only assignable to channel 1. This option will trigger 1 pulse per totalizer count for both the forward and reverse flow
#2 IMP +	Pulse on output 2 for forward flow rate. Only assignable to channel 2. This option will trigger 1 pulse per totalizer count for the forward flow totalizer.
#2 IMP -	Pulse on output 2 for reverse flow rate. Only assignable to channel 2. This option will trigger 1 pulse per totalizer count for the reverse flow totalizer.
#2 IMP	Pulse on output 2 for forward and reverse flow rate. Only assignable to channel 2. This option will trigger 1 pulse per totalizer count for both the forward and reverse flow
#1 FREQ+	Frequency on output 1 for forward flow rate. Only assignable to channel 1. This option will trigger a frequency output for forward flow.
#1 FREQ-	Frequency on output 1 for reverse flow rate. Only assignable to channel 1. This option will trigger a frequency output for reverse flow.
#1 FREQ	Frequency on output 1 for forward and reverse flow rate. Only assignable to channel 1. This option will trigger a frequency output for both forward and reverse flow.
#2 FREQ+	Frequency on output 2 for forward flow rate. Only assignable to channel 2. This option will trigger a frequency output for forward flow.
#2 FREQ-	Frequency on output 2 for reverse flow rate. Only assignable to channel 2. This option will trigger a frequency output for reverse flow.
#2 FREQ	Frequency on output 2 for forward and reverse flow rate. Only assignable to channel 2. This option will trigger a frequency output for both forward and reverse flow.

NOTE: Only the highlighted options are available for the SPI.

Table 3: Outputs available for open collector transistor outputs #1 through #4.

Function Symbol	Function Explanation
SIGN	Flow direction output (energized = reverse flow)
RANGE	Not Supported
MAX AL+	Max. forward flow rate output (energized = alarm off)
MAX AL-	Max. reverse flow rate output (energized = alarm off)
MAX AL	Max. forward and reverse flow rate output (energized = alarm off)
MIN AL+	Min. forward flow rate output (energized = alarm off)
MIN AL-	Min. reverse flow rate output (energized = alarm off)
MIN AL	Min. forward and reverse flow rate output (energized = alarm off)
MAX+MIN	Max. and min. flow rate alarm output (energized = alarm off)
EMPTY PIPE	Empty pipe alarm output (energized = alarm off)
OVERFLOW	Out of range alarm output (energized = flow rate is in range)
Hardw AL.	Cumulative alarm output; interrupt coils, empty pipe, and/or measure error (energized = alarms off)
EXT. COMM.	Not Supported

NOTE: Only the highlighted options are available for the SPI.

Table 4: CURRENT VALUES IN mA ASSOCIATED TO THE % VALUE OF FULL SCALE

POSSIBLE FIELD	REVERSE FLOW VALUE		ZERO	DIRECT FLOW VALUE	
	≤ - 110%	-100%	0%	+100%	≥+110%
OutmA= 0 ÷ 20 +	0	0	0	20	20
OutmA= 0 ÷ 22 +	0	0	0	20	20
OutmA= 4 ÷ 20 +	4	4	4	20	20
OutmA= 4 ÷ 22 +	4	4	4	20	20
OutmA= 0 ÷ 20 -	20	20	0	0	0
OutmA= 0 ÷ 22 -	22	20	0	0	0
OutmA= 4 ÷ 20 -	20	20	4	4	4
OutmA= 4 ÷ 22 -	22	20	4	4	4
OutmA= 0 ÷ 20	20	20	0	20	20
OutmA= 0 ÷ 22	22	20	0	20	22
OutmA= 4 ÷ 20	20	20	4	20	20
OutmA= 4 ÷ 22	22	20	4	20	22
OutmA= 0 ÷ 20 —0+	0	0	10	20	20
OutmA= 0 ÷ 22 —0+	0	1	11	21	22
OutmA= 4 ÷ 20 —0+	4	4	12	20	20
OutmA= 4 ÷ 22 —0+	4	4.8	12.8	20.8	22

NOTE: mA outputs 1 & 2 should be set to **4 ÷ 20+**.

9.11 Menu 7 - Communication

9.11.1 IF2 pr.

Protocol for IF2 port. Set to DPP or HTP. This set the protocol used for communication to the IF2 device, either Data Packet Protocol (DPP) or Hyper Text Protocol (HTP). Default is DPP.

9.11.2 RS485 bps

RS485 output speed. This sets the RS485 baud rate (4800, 9600, 19200, or 38400).

9.11.3 A. delay

Instrument answer delay. This sets the answer delay in microseconds (0, 20, 40, 60, 80, 100, 120, or 140).

9.11.4 Address

DEVICE ADDRESS (0 to 255) – This sets the address of the device for RS485 communication.

9.11.5 Rem. addr.

REMOTE ADDRESS (0 to 255) – This sets the address of a second remote converter.

9.11.6 Remote u.conn.

Pressing this connects the remote terminal. The connection will be interrupted after 10 seconds of inactivity

9.12 Menu 8 - Display

9.12.1 Language

This sets the converter language EN (English), IT (Italian), FR (French), SP (Spanish), or DE (German).

9.12.2 Contrast

Display contrast set point. The display contrast can be changed to make the display appear more visible based on user preference. This menu can be set 0 to 15. The change will take affect once the menu selection has been selected by pressing the Enter/Esc key. The factory default is 5.

NOTE: if set to high or too low the display can become unreadable. If this happens then wait 60 seconds from the time of the last button push for the display to time out to the visualization page. From the visualization page press and hold the Right/Left button. The display will cycle through a different preset display contrast settings every 8 seconds. Release the button once you have found a setting that can be read.

9.12.3 Quick start

Quick Start Menu Enable. This setting toggles between on and off. If set to "off" it will hide the quick start menu.

9.12.4 Net total

Totalizer Net Enable. This setting toggles between on and off. Setting this menu to on will replace the current forward and reverse totalizers with the net totalizers on the visualization.

9.12.5 T+ reset

Totalizer reset, forward. Resets the forward flow totalizer.

9.12.6 T- reset

Totalizer reset, reverse. Resets the reverse flow totalizer.

To reset the totalizer, highlight the totalizer reset option to be reset. Quick press the Enter/Esc key. The display will show "EXECUTE?". Press and hold the Enter/Esc to continue. The display will flash "Done". The visualization pages will now show the totalizer as reset.

NOTE: There is no function to reset the Net Totalizer. Reset both the "+" and the "-" totalizers to reset the Net total.



9.13 Menu 9 - Data Logger

9.13.1 YYYY/MM/DD

Date and time. This sets the date and time in the converter. The format for entering the date and time is year / month / day and time is hours : minutes : seconds.

9.13.2 Acquisition

Event logger for internal alarms. This setting toggles between on and off. This menu enables event logging to capture alarm events internally for diagnostic purposes. This data can't be extracted.

9.13.3 Display events

Displays the stored alarm events on-screen in order up to a maximum of 64 events.

9.13.4 Clear events

Clears all stored events.

9.14 Menu 10 - Diagnostics

9.14.1 Self-test

Converter self-test. Executed command. Running the self-test will cause the converter to run an internal diagnostic test that will check for internal hardware and software errors. The converter will reboot. Once the self-test is complete if any errors are found then the error code for each error will be displayed. Contact factory for support.

9.14.2 Simulation

Simulation enable. Setting this menu to ON will generate an internal signal that simulates flow and allows the outputs and all connected instruments to be tested. After simulation is set to ON, the flow can be set to a percentage based on the current FS1 setting of -125% to 125%.

To enable the simulation function, use the Right/Left key to highlight the Simulation menu and press the Enter/ Esc key. Toggle the simulation function from OFF to ON using the Up/Down key. Press and hold the Enter/ Esc key to exit back to the main menu and once again to exit to the visualization page.

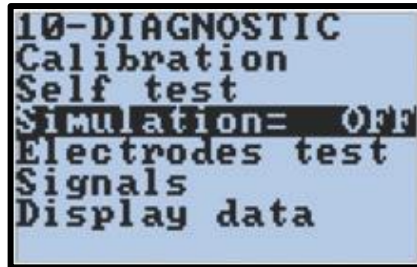

NOTE: you will now have an “S” in the upper left corner; this indicates the simulation mode is active.

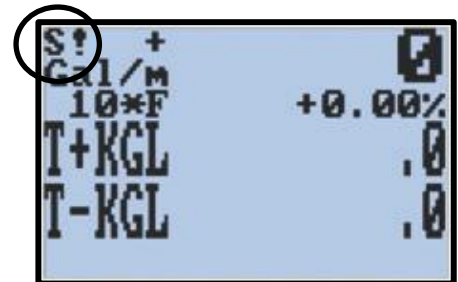

Press the Enter/Esc key. This will bring up the flow simulation set up screen. Use the Right/Left key and the Up/ Down key to enter in the flow rate percentage value for the simulation. Press the Enter/Esc key to enter that value.

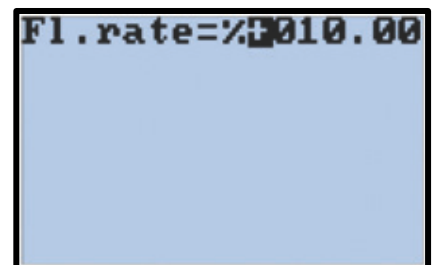

The converter will start to read flow. It may take a few seconds for the readings to appear. Repeat the above steps as needed to observe the different flow rates desired.

To exit out of simulation mode, re-enter into the simulation set up screen (see above) and then press and hold the Enter/Esc key. This will exit out to the visualization screen, and the “S” in the upper left corner of the screen will return to a “1”.

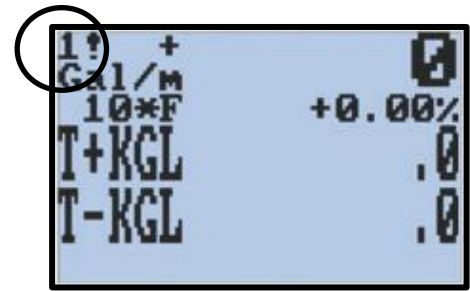

9.14.3 Electrodes test

Executed function. This function tests the internal electrode circuits for proper operation. This is a factory service menu.

9.14.4 Signals

This menu displays graphical representations to various input and output signals. This is a Factory service menu.

9.14.5 Display data

Numeric display for various internal settings and raw measured signals. This is a Factory service menu.

9.15 Menu 11 - Internal Data

9.15.1 L2 code

Level 2 passcode. This menu changes the 2 level passcode. The factory default is **000002**



CAUTION - if the passcode is changed from the default value and is lost, it **CANNOT** be recovered. In the event the passcode is lost the converter can be returned to the factory to be reset. Note all data is lost during this process.

9.15.2 Load fact. Pres.

Load factory presets. This is an executed menu. Executing this menu will reset all programmed values to the original factory default values.

NOTE: This menu is customized for a specific sensor. Confirm the converter has not been moved or paired with another sensor prior to executing this menu.

9.15.3 Load user pres.

Load User Presets. This is an executed menu. Executing this menu will reset all programmed values to a user defined set of programming values. These values are set using the "Save user pres." Menu.

To reload the factory or user presets select the desired set of presets by highlighting the menu and press the Enter/Esc key.

```

11-INTERNAL DATA
L2 code= *****
Load fact. pres.
Load user pres.
Save user pres.
KS=      +01.0000
KZ=      +000000
KZ-=     +000000
    
```

```

11-INTERNAL DATA
L2 code= *****
Load fact. pres.
Load user pres.
Save user pres.
KS=      +01.0000
KZ=      +000000
KZ-=     +000000
    
```

You will be asked if you want to "execute?" the function. Press and hold the Enter/Esc key. This will load the saved preset values. The display will flash "DONE" once the converter has finished reprogramming the preset values.

```

11-INTERNAL DATA
L2 code= *****
Execute?
Load user pres.
Save user pres.
KS=      +01.0000
KZ=      +000000
KZ-=     +000000
    
```

```

11-INTERNAL DATA
L2 code= *****
DONE
Load user pres.
Save user pres.
KS=      +01.0000
KZ=      +000000
KZ-=     +000000
    
```

9.15.4 Save user pres.

Saves user presets. This is an executed menu. To save a user defined program start by reviewing each and every programming menu and confirm that each value is set as desired. Once it is confirmed the programming is set as desired, navigate to the “Save user pres.” menu and press the Enter/Esc key. You will be prompted if you want to “execute?”. Press and hold the Enter/ Esc key and the display will flash “DONE”. Your user defined presets have now been saved and can be recalled anytime by executing the “Load user pres.” function.

```

11-INTERNAL DATA
L2 code= *****
Load fact.pres.
Load user pres.
Save user pres.
KS=      +01.0000
KZ=      +000000
KZ-=     +000000
    
```

```

11-INTERNAL DATA
L2 code= *****
Load fact.pres.
Load user pres.
EXECUTE?
KS=      +01.0000
KZ=      +000000
KZ-=     +000000
    
```

```

11-INTERNAL DATA
L2 code= *****
Load fact.pres.
Load user pres.
DONE
KS=      +01.0000
KZ=      +000000
KZ-=     +000000
    
```

9.15.5 KS

Field adjustment coefficient. This value is a direct multiplier that is used as a field adjustment/correction coefficient.

9.15.6 KZ

Forward zero point coefficient. The forward zero point coefficient is selected when the zero calibration is run. This menu will allow for manual adjustments of the forward zero point.

9.15.7 KZ-

Reverse zero point coefficient. Used ONLY for forward and reverse sensors. The reverse zero point coefficient is selected when the zero calibration is run. This menu will allow for manual adjustments of the reverse zero point

9.15.8 DAC1 20mA

Current output channel 1 20 mA trim. This is a factory service menu.

9.15.9 DAC1 4mA

Current output channel 1 4 mA trim. This is a factory service menu.

9.15.10 DAC2 20mA

Current output channel 2 20 mA trim. This is a factory service menu.

9.15.11 DAC2 4mA

Current output channel 2 4 mA trim. This is a factory service menu.

10 Alarm Messages

During meter setup, you may see alarm messages. These alarms and some common solutions are explained in Table 5 below. Contact factory for further support.

Table 5: Alarm Messages

MESSAGES	ANOMALIES	ACTION TO TAKE
NO ALARMS	Everything works regularly	--
MAX ALARM	The flow rate is higher than the maximum threshold set	Check the maximum flow rate setting and process conditions. (Menus Max Thr and +Fs1)
MIN ALARM	The flow rate is lower than the minimum threshold set	Check the minimum flow rate threshold setting and process conditions. (Menu +Fs1)
FLOW RATE >FS	The flow rate is higher than the full scale value set on the instrument	Check the full scale value setting on the instrument and the process conditions/ (Menu Fs1)
PULSE/FREQ .FS	The output channel is saturated.	Set a bigger frequency unit or, if the connected counting device allows it, reduce the pulse duration value. (Menu Tpls)
EMPTY PIPE	The measuring pipe is empty or the detection system has not been properly calibrated	Check whether the pipe is empty.
INPUT NOISY or MEASURE ERROR	The measure is strongly effected by external noise or the cable connecting the converter to the sensor is broken	Check the status of the cables connecting the sensor, the grounding connections of the devices or the possible presence of noise sources
EXCITATION FAIL	The coils or the cable connecting the sensor are interrupted	Check the connecting cables to the sensor
CURR. LOOP OPEN	The 0/4-20ma output on board or the optional one are not correctly closed on a valid load	Verify the load is applied to the output (max 1000 ohm) or a resistor is in place. To disable the alarm, set the "mA VAL.FAULT" value (menu alarm) to 0.



11 Troubleshooting Guide

Table 6 below provides suggestions for fixing common problems. Contact factory for further support.

Table 6: Troubleshooting

Problem	Troubleshooting Steps
Not getting expected 4-20mA output	<ul style="list-style-type: none"> • Ensure the wiring is firmly connected on the 4-20mA output terminals • Verify the FS1 setting in the Quick Start menu is set to the correct value • Measure output on the 4-20mA terminals and compare it to the calculated current value
Curr. Loop Open Alarm	<ul style="list-style-type: none"> • Ensure the wiring is firmly connected on the 4-20mA output terminals and terminated on both ends. • If the 4-20mA output is not being used, ensure the 4- 20mA terminals have a load resistor installed • Remove the wires from the 4-20mA terminals and measure the current output direct
Excitation Fail (0800) Alarm	<ul style="list-style-type: none"> • Ensure the wiring is firmly connected • Disconnect the coil wires from the converter and check their resistance with a standard multi-meter. Contact the factory for the proper value for the sensor. • Ensure the wiring is firmly connected to any PreAmp being used.
Noisy Input Alarm	<ul style="list-style-type: none"> • Verify there is a jumper on terminals 3 and 4 • Verify the converter ground is to earth ground • Check for damaged cable between the sensor and converter
Empty Pipe Alarm	<ul style="list-style-type: none"> • Confirm the pipe is full • Verify there is a jumper on terminals 3 and 4 • Check EP Threshold. Set to 192 if short cable (less than 50 ft.), set to <120 if longer cable (50 ft. to 100 ft.). Consult the factory for assistance in selecting the correct value. • Conduct a bucket test to confirm the EP Threshold value is set correctly. Consult the factory for assistance. • Check for damaged cable between the sensor and converter
Unstable Flow Readings	<ul style="list-style-type: none"> • Check grounding connections • Check power circuit. What other devices are on the circuit • Install dedicated ground circuit
Menu Not Accessible	<ul style="list-style-type: none"> • Confirm the password being used is 000002 • Verify dip switches in the back panel next to the terminals 1 and 2 are both down.
Rate Of Flow Report Is Not As Expected	<ul style="list-style-type: none"> • Confirm the unit is programmed correctly by requesting a program setting report from the factory.

12 Appendix

12.1 Installation Guide

Purpose:

To provide a step by step procedure for installing the SPI flow meter inline to ensure correct insertion depth and calibration.

12.1.1 SPI Probe Installation:

Step 1:

Ensure you have a 1" NPT drilled hole on the inlet of the valve.



Step 2:

Put a generous amount of thread sealant on the pipe nipple and thread it into the 1" NPT hole on the valve



Step 3:

Put a generous amount of lock tight on the other side of the pipe nipple and thread the compression nut on the pipe nipple. Ensure there is an o-ring in the compression nut on the sensor side.



Step 4:

Tighten the compression nut which in turn will tighten the pipe nipple. Tighten till hand tight to ensure tight water seal. Ensure the ready rod threading holes are horizontal in final tightened position.



Step 5:

Put some anti-seize on the ready rod and thread the rod into the upstream side of the compression nut. Once threaded tighten set screw



Step 6:

Measure the Length of the Probe, the Boss Length, and the Inner Diameter (also shown in Converter Quick Start Menu)..

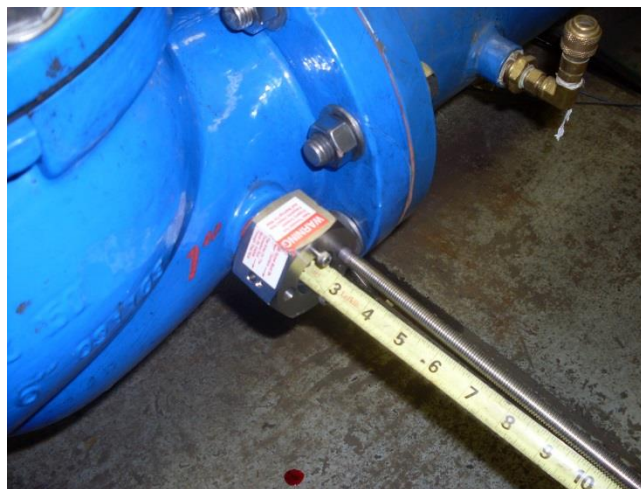

Calculate the insertion depth based on the measured values:



- **LENGTH OF PROBE (L)** is measured from the middle of the electrodes on the sensor to the end of the sensor.
- **BOSS LENGTH (B)** is a measurement from the inner of the valve to the end of the compression nut. This is the Fittings & Body Width
- **0.125D** is the insertion depth of the probe into the valve. This is 1/8 of the internal diameter of the valve

Step 7:

Insert the SPI sensor ensuring the flow arrow points down steam and tighten the nut with the socket wrench provided with the SPI package.



Step 8:

Tighten till the correct insertion depth and tighten the compression clamp. Once the compression clamp tightens on the o-ring the SPI sensor is sealed



Step 9:

Ensure both the compression nut and SPI sensor are horizontal to ensure correct sensor alignment.



12.1.2 Converter Wiring Installation:



Step 1:

Locate and pull the rip wire on the sensor cable. Open the back of the Converter.



Step 2:

Thread the sensor cable through the enclosure connection and tighten the enclosure connector.



Step 3:

Install the Sensing Electrodes, Reference Ground, Coils and Shield wires. Take note of how the Ground and Shield black wires are heat wrapped separately to indicate which wire is which.



Terminal	Wire Colour	Connection
#1	Blue	Sensing Electrode
#2	White	Sensing Electrode
#3	Black	Reference Ground
#19	Black	Cable Shield
#20	Red	Coil
#21	Yellow	Coil

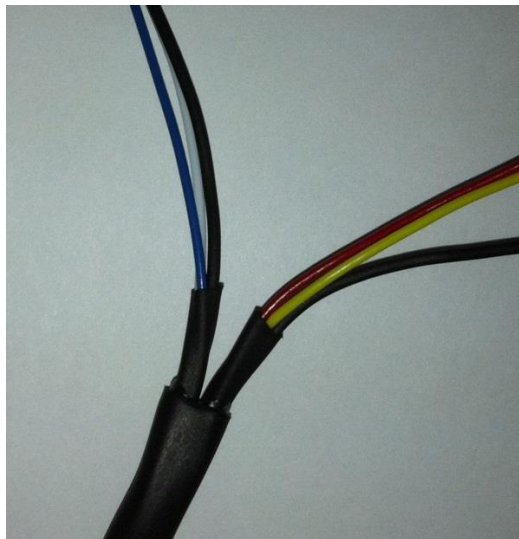

Step 4:

Install power cable provided with SPI package. Thread the power cable through the enclosure connections and tighten the enclosure connector. Install Line (black), Neutral (white), Ground (green) wires.



Step 5 (Optional):

Installing the 4-20mA wiring can be done in 1 of 2 outputs or both. Note there are load resistors that need to remain unless the 4-20mA current loop is being used. To install wiring for 4-20mA remove only the load resistor of the output you are using.

Output 1: Common 27 & Output 25

Output 2: Common 27 & Output 26

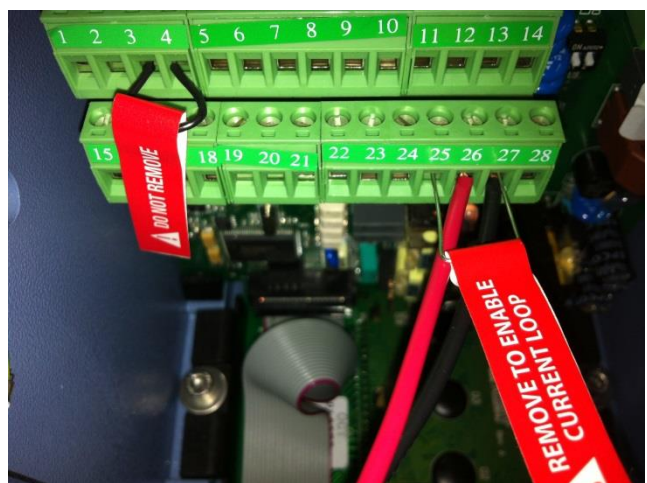
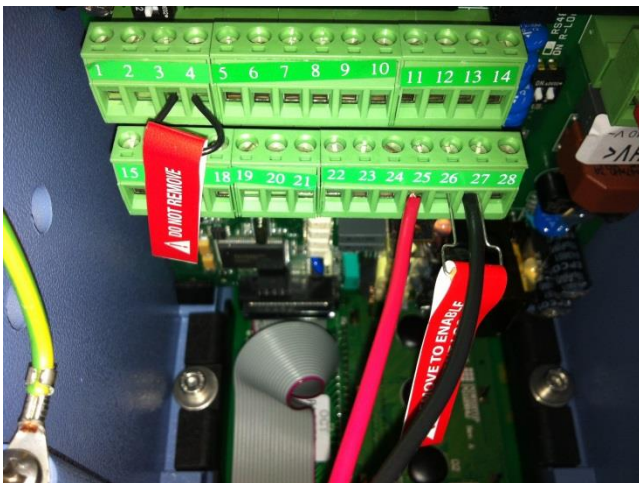

12.2 Installation Record

The following table can be used to record probe insertion measurements for reinsertion after maintenance.

Date	Sensor Length (C)	Nipple & Nut Length (B)	1/8 Valve Diameter (A)	Insertion Depth (Y)

12.3 Units of Measure

The units available for Full Scale Range (FS1) and Totalizer (Tot.MU) in the Converter are shown in the tables below:

U.S Standard	
Gal	U.S. Gallons
IGL	Imperial Gallons
KGL	Thousand Gallons
IKG	Thousand Imperial Gallons
ttG	Ten Thousand Gallons
MGL	Mega Gallons*
in ³	Cubic Inches*
ft ³	Cubic Feet
hf ³	Hundred Cubic Feet
kf ³	Thousand Cubic Feet
Ain	Acre Inches
Aft	Acre Feet
bbl	Standard Barrels
BBL	Oil Barrels

Metric	
ml	milliliters*
l	Liters
dal	Decaliter
hl	Hectoliter
MI	Megaliters
cm ³	Cubic Centimeters*
dm ³	Cubic Decimeter
m ³	Cubic Meters

Time	
s	Seconds
m	Minutes
h	Hours
d	Days

*These units only available for the Totalizer (Tot. MU)



Please read and understand the contents of this manual.